

# Fast Regulation of Photosynthesis in Diatoms: Mechanisms, Evolution and Ecophysiology

Johann Lavaud

Group of Plant Ecophysiology, Biology Department, Postfach M611, University of Konstanz, Universitätsstraße 10, 78457 Konstanz, Germany

Correspondence: Johann.Lavaud@uni-konstanz.de

## ABSTRACT

Diatoms (Bacillariophyceae, Heterokontophytes) are essential aquatic eukaryotes. Their role in the structure and ecology of most of the aquatic ecosystems is crucial. Especially, their photosynthetic activity is responsible for about a quarter of the Earth's primary productivity as large as the most productive terrestrial ecosystems, even though they represent only few percents of the total plant biomass on the planet. Both planktonic and benthic diatoms tend to dominate in ecosystems characterised by a high turbulence of the water (coasts and estuaries). As a consequence, they have to cope with an underwater light climate with high frequency fluctuations in irradiance coupled with large amplitude. The observation that diatoms grow and dominate under a fluctuating light regime regularly punctuated with excess light exposure, which can be harmful for photosynthesis activity, suggests both an unusual flexibility and ability to protect from light stress. These abilities arise from fast photoprotective processes which allow the diatoms to rapidly regulate the absorption, transfer and use of the light energy used for photochemistry and ultimately for biomass production. While largely studied in higher plants, the function and peculiarities of these mechanisms just start to come to light in diatoms. Here, after a description of the composition and organisation of the photosynthetic apparatus of the diatoms, the main fast photosynthetic regulatory processes are described, their evolution discussed and their possible involvement in the ecophysiology of diatoms in the context of water vertical mixing highlighted.

**Keywords:** cyclic electron transport, fluctuating light, light-harvesting complex, non-photochemical quenching, photoacclimation, photo-protection, xanthophyll

**Abbreviations:** AX, antheraxanthin; Chl *a*, *b* and *c*, chlorophyll *a*, *b* and *c*; DD, diadinoxanthin; DDE, DD de-epoxidase; DEP, DT epoxidase; DT, diatoxanthin; FCP, FX Chl protein (=‘LHCF’); FX, fucoxanthin; LHC, light-harvesting complex; PBS, phycobilisomes; PQ, plastoquinone; PS I and II, photosystem I and II; PS II CET, PS II cyclic electron transport; NPQ, non-photochemical Chl fluorescence quenching; qE, the energy-dependent part of NPQ; ROS, reactive oxygen species; UV, ultra-violet; VDE, VX de-epoxidase; VX, violaxanthin; XC, xanthophyll cycle; ZEP, ZX epoxidase; ZX, zeaxanthin

## CONTENTS

INTRODUCTION.....	267
Composition and organization of the photosynthetic apparatus in diatoms .....	268
The light-harvesting pigments .....	269
The biosynthetic pathway of the xanthophylls .....	270
The organization of the light-harvesting complex (LHC) antenna.....	271
Fast regulation of the diatom photosynthesis in an underwater light fluctuating environment.....	273
The xanthophyll cycle, XC.....	274
The non-photochemical Chl fluorescence quenching, NPQ.....	275
High light and ultra-violet (UV) radiation regulation of the XC and NPQ.....	277
The photosystem II electron cycle, PSII CET.....	278
An evolutionary point of view of the fast photosynthetic regulatory mechanisms .....	279
A possible role for the fast photoprotective mechanisms in the ecophysiology of diatoms .....	280
CONCLUSION AND PROSPECTS .....	281
ACKNOWLEDGEMENTS .....	282
REFERENCES.....	282

## INTRODUCTION

Diatoms are a major group of planktonic and benthic microalgae being present in all marine and freshwater aquatic ecosystems (Round *et al.* 1990). With 10000 species, their biodiversity is one of the largest among photosynthetic organisms, just after the higher plants (Mann 1999). Diatoms contribute to more than 40% of the aquatic primary production (20 Pg C/year, i.e. 25% of the Earth's yearly production) (Smetacek 1999), a production equivalent to two of the most productive terrestrial ecosystems: the tropical for-

ests and the savannas (Field *et al.* 1998). Diatoms also play a central role in the biogeochemical cycles of silica (which is part of their cell-wall) and nitrogen (Smetacek 1999; Villareal *et al.* 1999; Sarthou *et al.* 2005). Especially in the ‘up-welling’ areas of the West coast of America and Africa (coastal zones of upward movement of deep waters enriched in nutrients), the diatoms sustain much of their productivity which maintains local economy and particularly the fisheries (Falkowski 1994; Falkowski *et al.* 1998). All in all, it explains why the diatoms have been largely contributing to the productivity and the shaping of the structure

of contemporary aquatic ecosystems (Falkowski *et al.* 2004; Tozzi *et al.* 2004). They are also believed to have a strong historical impact on global climate by being a major source of carbon export production (Falkowski *et al.* 1998; Smetacek 1999; Sarthou *et al.* 2005). This activity has been suggested to be partially regulated by the biogeochemical cycle of the silica through its specific influence on the species composition of phytoplankton and diatom communities, and on their productivity (Harrison 2000; Tréguer and Pondaven 2000). Indeed, as silica is needed by diatoms to build up their siliceous cell-wall, an increase in the oceanic silica (from land dust deposal and partial dissolution) favours the growth of diatoms over non-siliceous species of phytoplankton (Tréguer and Pondaven 2000). The recent publication of the genome from two species, *Thalassiosira pseudonana* (Armbrust *et al.* 2004) (<http://genome.jgi-psf.org/Thaps3/Thaps3.home.html>) and *Phaeodactylum tricorutum* (<http://genome.jgi-psf.org/Phatr2/Phatr2.home.html>), has opened new perspective in diatom research, starting from their physiology and metabolism. The new genomic data also brought some light on the special origin and evolution of the diatoms which have been unavoidably influencing the regulation of their metabolism. Indeed, diatoms (as all Heterokontophytes) originate from a secondary endosymbiotic event in contrast to the primary endosymbiotic origin of the 'green lineage' (among which the green algae and the higher plants) (Keeling 2004). It is believed that the diatoms derived from a non-photosynthetic eukaryote which engulfed and maintained a eukaryotic photosynthetic cell close to a red alga which evolved into a plastid (Oudot-Le Secq *et al.* 2007). For that reason, the genome of *T. pseudonana* shows many genes/proteins aligning not only with the green and red photosynthetic organism genomes but also with homologues of animal origin (Armbrust *et al.* 2004). This special origin and evolution have led to complex cell functions (Montsant *et al.* 2007) and metabolic regulations based on dynamic exchanges between the three main organelles of the cell (the nucleus, the mitochondria and the plastid(s)). This situation is at the basis of a peculiar physiology, particularly regarding photosynthesis, for which specificities just start to come to light (Allen *et al.* 2006; Wilhelm *et al.* 2006).

As for all phytoplankton organisms, the photosynthetic efficiency of diatoms, and subsequently their productivity, strongly depends on the underwater light climate through which they are passively transported by water motions (Lewis *et al.* 1984; Fogg 1991; MacIntyre *et al.* 2000; Lichtman and Klausmeier 2001). The underwater light climate can be highly variable due to the optical properties and the turbulent diffusivity of water which depend on the water body itself (MacIntyre *et al.* 2000). Unlike nutrient availability and temperature, fluctuations in irradiance can show very high frequency (few seconds) coupled with high amplitude (from darkness to full sunlight) (Lewis *et al.* 1984; MacIntyre *et al.* 2000; Raven and Geider 2003). Planktonic diatoms are usually abundant in marine and fresh turbulent waters and during periods of turbulence (Fogg 1991; Huisman *et al.* 2004; Sarthou *et al.* 2005). Also, they largely dominate the microphytobenthic community, especially in muddy and/or sandy estuarine flats where they are submitted to extreme light conditions (Barranguet *et al.* 1998; Blanchard *et al.* 2004). For example, cells acclimated to low irradiances as the ones encountered at the bottom of the photic zone can be rapidly transported to the surface (or benthic species resuspended with the up-tide) where they can be exposed to excess light possibly generating stressful conditions (Neale 1987; Fogg 1991; Long *et al.* 1994). Both punctual and chronic high light exposures have been showed to impair the photosynthesis of phytoplankton, decreasing up to 25% the water column primary productivity as a function of the mixing rate (Long *et al.* 1994; Falkowski and Raven 1997; Oliver *et al.* 2003), and to strongly influence the species succession of phytoplankton (Flöder *et al.* 2002).

Diatoms are known to be able to survive large fluctuations in irradiance, from full sunlight (visible light and

ultra-violet, UV, radiations) at the surface to darkness below the photic zone (Richardson *et al.* 1983; Fogg 1991). Also it has been shown that the growth rate and the photosynthetic capacity of diatoms are not/less affected by light fluctuations in contrast to the green algae, cyanobacteria and dinoflagellates species examined so far (Nicklisch 1998; Litchman 2000; Mitrovic *et al.* 2003). These observations fit with several experiments conducted in coastal marine and freshwater mesocosms and in controlled nutrient and mixing conditions (Estrada and Berdalet 1997; Petersen *et al.* 1998) as well as with the simulation of species succession and diatom dominance in lakes (Huisman *et al.* 2004). Hence, diatoms have to cope with the fluctuation in the supply of light energy which is a major drawback for photosynthetic organisms. The ability of diatoms to grow and dominate under a light environment showing large fluctuations in irradiances suggests an unusual photosynthetic flexibility, especially in harvesting and using the light energy over very short time scales of the second/minute order. The goal of the following review is to describe and discuss the mechanisms that the diatoms evolved in order to cope with the high frequency and high amplitude changes in irradiance they are submitted to in their natural environment.

### Composition and organization of the photosynthetic apparatus in diatoms

In general, centric diatoms (like *T. pseudonana*) have many small plastids while pennates (like *P. tricorutum*) have several larger ones and even only one which can occupy half of the volume of the cell (**Fig. 1A**). In diatoms, as well as in other Heterokontophytes, the plastid ultrastructure and the organization of the photosynthetic apparatus differ in many respects from that of higher plants due to their peculiar evolutionary origin (Pyszniac and Gibbs 1992; Kroth and Strotmann 1999; Oudot-Le Secq *et al.* 2007). The thylakoids are grouped by bands of three all along the plastid (**Fig. 1B**) and they are not very tightly associated since they are spaced by 2 nm (Pyszniac and Gibbs 1992). They are surrounded by a band of three thylakoids, the so-called 'girde stack'. In contrast to higher plants, there are no grana stacking so that the distribution of the photosystems (PS) I and II is homogeneous all along the membranes without segregation among the stacked and external areas (stroma side), even if it has been sometimes observed that the PS I tend to concentrate on the stroma side. This observation has been reported for the diatoms, but also other members of the Heterokontophytes: the Phaeophyceae or 'brown algae', and the Chrysophyceae (Lichtlé *et al.* 1992; Pyszniac and Gibbs 1992; Lichtlé *et al.* 1995). Nevertheless, the homogeneous distribution of photosystems is not true for all Heterokontophytes like the Xanthophyceae (Büchel and Wilhelm 1992). Also, in diatoms and other Heterokontophytes, the distribution of the pigmented light-harvesting complex (LHC) antenna subunits is homogeneous along the thylakoid membranes (Lichtlé *et al.* 1992; Pyszniac and Gibbs 1992; Lichtlé *et al.* 1995). Some protocols allowing the isolation of functional plastids from some species (especially *Odontella sinensis*) are available (Martinson *et al.* 1998; Wittpoth *et al.* 1998). The entire or partial plastid genome of four species (*O. sinensis*, *Skeletonema costatum*, *T. pseudonana* and *P. tricorutum*) are also available (Kowallik *et al.* 1995; Tada *et al.* 1999; Oudot-Le Secq *et al.* 2007). These plastid genomes clearly show remnants of red algal origin, tracing back the evolutionary origin of diatom plastids (Keeling 2004; Oudot-Le Secq *et al.* 2007).

Diatoms also have a set of specific pigments among which the xanthophylls are very abundant, giving them their characteristic brown-yellow color (Wilhelm 1990). The LHC subunits, which bind these pigments, are composed of several highly homologous proteins encoded by a multigene family: the FCPs for 'Fucoxanthin Chlorophyll Proteins' (also named LHCF for 'LHC containing Fucoxanthin') (Bhaya and Grossman 1993). FCPs show high sequence similarity among the Heterokontophytes (Green and Durn-

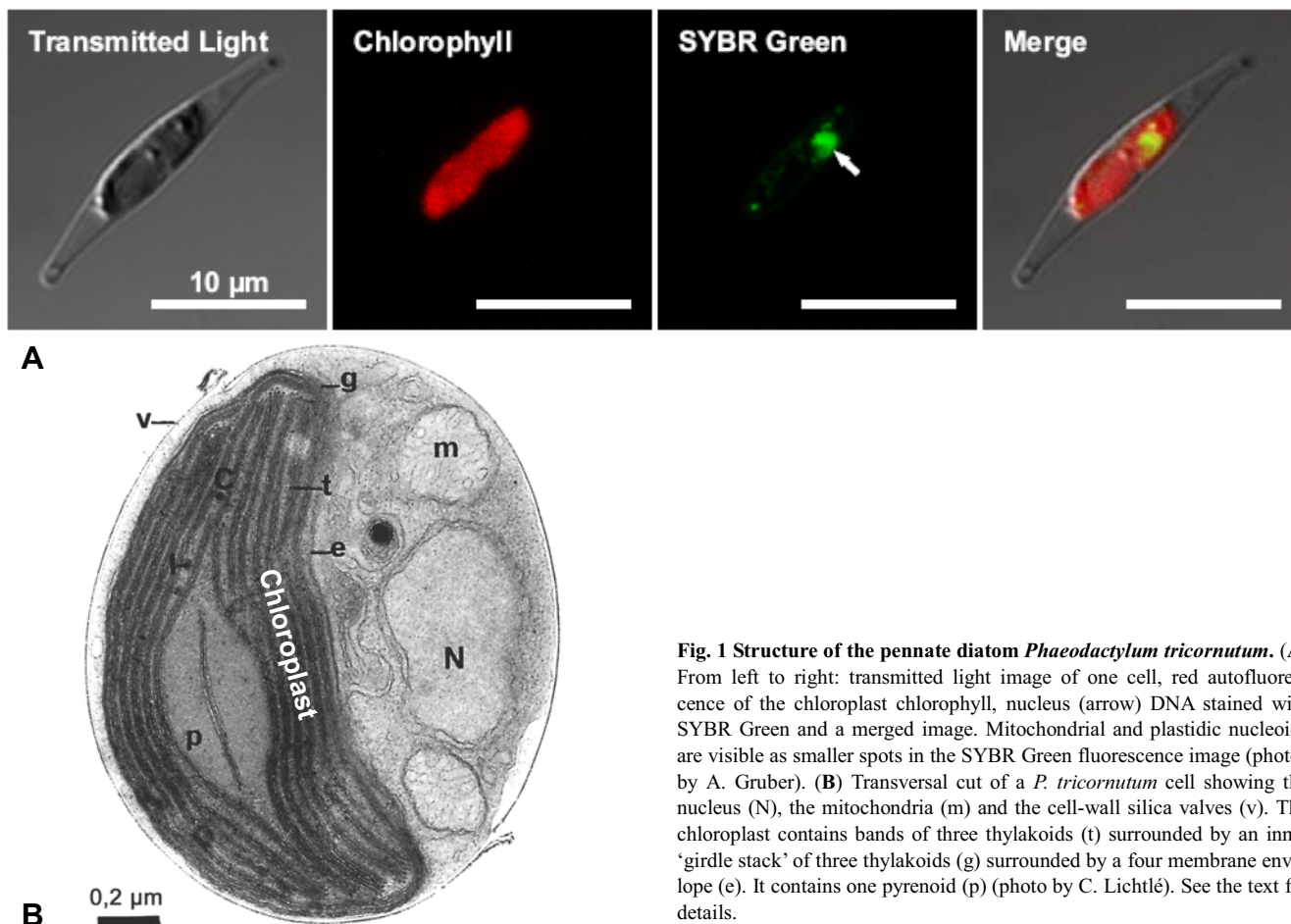

**Fig. 1 Structure of the pennate diatom *Phaeodactylum tricorutum*.** (A) From left to right: transmitted light image of one cell, red autofluorescence of the chloroplast chlorophyll, nucleus (arrow) DNA stained with SYBR Green and a merged image. Mitochondrial and plastidic nucleoids are visible as smaller spots in the SYBR Green fluorescence image (photos by A. Gruber). (B) Transversal cut of a *P. tricorutum* cell showing the nucleus (N), the mitochondria (m) and the cell-wall silica valves (v). The chloroplast contains bands of three thylakoids (t) surrounded by an inner 'girdle stack' of three thylakoids (g) surrounded by a four membrane envelope (e). It contains one pyrenoid (p) (photo by C. Lichtlé). See the text for details.

ford 1996), especially between the diatoms and the brown algae (Caron *et al.* 1988; Apt *et al.* 1995; de Martino *et al.* 2000; Green 2003) Their organization *in vivo* is not well known but it recently appeared that LHC proteins can reach a high oligomeric state different from the one described in higher plants (Büchel 2003; Lepetit *et al.* 2007). The PS II and PS I complexes have been only very recently successfully purified in a pure native state; it is thus too premature to clearly state on their composition and spatial arrangement (Nagao *et al.* in press; Veith and Büchel in press).

Because of these specificities, which are essential for better understanding the fast regulation of photosynthesis in diatoms, the following chapters will focus on the pigment/protein composition and organization of the LHC system (a thorough review on the composition, organization and function of the photosystems in algae has been recently published by Nugent *et al.* 2003).

### The light-harvesting pigments

The first step in the photosynthetic process is the capture of light energy by pigments. The pigmentation of the diatoms, and consequently their absorption capabilities, differs considerably from the one of green algae and higher plants, which has a major influence on their photosynthetic performance in the aquatic environment.

In most of the green algae and higher plants, the chlorophylls *a* and *b* (Chl *a* and *b*) are the major pigments while the carotenoids/xanthophylls lutein, neoxanthin, violaxanthin (VX) and  $\beta$ -carotene contribute to both light-harvesting and photoprotection either directly or indirectly by being converted into a close form (like for VX, as described later) (Bassi and Caffarri 2000). In diatoms, Chl *b* is replaced by Chls *c* (Goedheer 1970; Stauber and Jeffrey 1988). Regarding the carotenoids, diatoms are not able of synthesizing carotenoids derived from the  $\alpha$ -carotene (like lutein) but only from the  $\beta$ -carotene pathway (Pennington *et al.* 1988).

The carotenoids/xanthophylls of diatoms, in contrast to plants, have a major role in harvesting light, the dominant one being fucoxanthin (FX) (Kirk 1977). Other xanthophylls present in significant amounts are the diadinoxanthin (DD) and diatoxanthin (DT). They are mainly involved in the rapid regulation of the light absorption/dissipation even though part of the DD pool also seems to be able to absorb and efficiently transfer the light excitation energy to Chl *a* (Wilhelm 1990; Lavaud *et al.* 2003). A third role for these xanthophylls, and especially FX, is the stabilisation of the LHC structure within the thylakoid membrane (Pascal *et al.* 1998). It is similar to the structural role of lutein in the green organisms (Kuhlbrandt *et al.* 1994). Another, yet unexplained difference between higher plants and diatoms concerns the stoichiometry of the pigments. The xanthophyll to Chl *a* stoichiometry can be 2-4 times higher than in plants with sometimes an equimolar distribution of xanthophylls and Chl in LHCs (Wilhelm 1990; Papagiannakis *et al.* 2005). The pigment content of diatoms is rather stable from a species to another under the same growing conditions with variations only concerning Chl *c* ( $c_1$ ,  $c_2$ ,  $c_3$ ) (Stauber and Jeffrey 1988; Brown 1989). The association of high amount of xanthophylls with Chl *c* is believed to be an adaptation of the diatom LHC, and to a larger extent of Chl *c*-containing algae, to maximize the harvesting of the relatively low intensities of blue-green light penetrating the water column (Richardson *et al.* 1983; Macpherson and Hiller 2003). Indeed, these pigments are responsible for extending the light harvesting abilities of the cells beyond the Soret (blue) band of Chl *a* up to the green part of the visible light spectrum (i.e. 570 nm) (Fig. 2).

Chl *c* is characterised by a higher symmetry and different ionic properties than Chl *a* and *b*. Consequently, Chl *c* shows a drastic decrease of the absorption band in the red region of the visible light spectrum (600-700 nm) (Fig. 2). Additionally, the absorption peak in the blue region (400-500 nm) is shifted by 25 nm when compared to Chl *a*. More

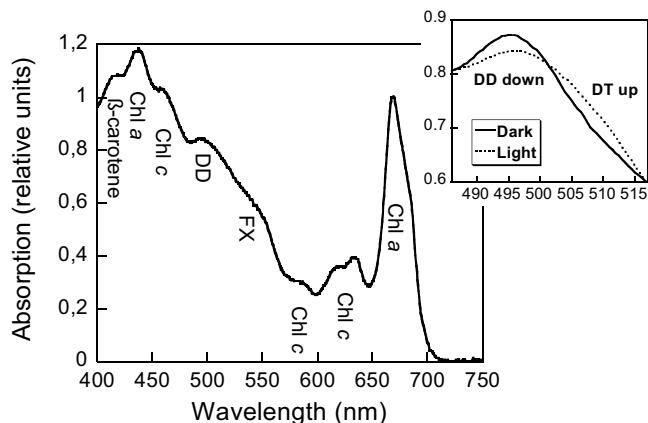

**Fig. 2** 77K absorption spectrum of dark-adapted cells of the diatom *Phaeodactylum tricornutum* diatom showing the absorption bands of each of the pigments. The spectrum is normalised to the maximum absorption band of Chl *a* in the red. Inset: enlargement of the 480-520 nm region showing the change in DD and DT amounts before (continuous line) and after (dashed line) exposure to high light intensity (adapted from Lavaud *et al.* 2003). Chl, chlorophyll; DD, diadinoxanthin; DT, diatoxanthin; FX, fucoxanthin. See the text for details.

details on the optical properties of Chl *c* are given by Larum (2003).

FX is an allenic xanthophyll only found in diatoms, other Heterokontophytes (like the 'brown algae') and in some the Dinophytes ('dinoflagellates') (Takeshita *et al.* 2004). The evolutionary acquisition of this pigment in the diatoms has been considered, similarly to the acquisition of phycobilisomes in Cyanophytes (cyanobacteria) and Rhodophytes (the 'red algae') and the acquisition of peridinin in the Dinophytes, as an adaptation to the marine underwater light climate for which the blue-green light radiations dominate from a certain depth (Kirk 1977). The main optical and quite unique spectroscopic characteristic of FX is the strong switch of its absorption band between bound (to proteins) and not bound conditions where it absorbs between 520-560 nm and at 460 nm, respectively (Fig. 2) (Goedheer 1970; Kirk 1977). This phenomenon is not well explained but it is used to check the native state of isolated LHCs by surveying the energy transfer and thereby the state of the connection between FX and Chl *a* (Büchel 2003; Lavaud *et al.* 2003).

DD (also found in some other groups of the Heterokontophytes and in the Dinophytes) is also a carotenoid of allenic xanthophyll type. As most of the carotenoids, it absorbs between 400 and 500 nm with an *in vivo* maximum around 490-495 nm (Fig. 2) (Lavaud *et al.* 2003; Ruban *et al.* 2004). Even though DD seems to participate into the harvesting of light (Wilhelm 1990), its effective importance remains low (Lavaud *et al.* 2003). DD can be de-epoxidised into DT under an excess light exposure, the two pigments forming the so-called 'xanthophyll cycle' (XC) (Stransky and Hager 1970). This pigment conversion can be readily observed by absorption changes of the disappearance of the DD peak and the appearance of the 508-512 nm band specific of DT (Olaizola and Yamamoto 1994; Lavaud *et al.* 2003; Ruban *et al.* 2004) (see inset, Fig. 2). DT plays a central role in the photoprotection of the photosynthetic apparatus. Details are given later on the regulation and physiological significance of the XC in photoprotection.

The overall amount of these pigments, and especially of xanthophylls, is highly variable with culture conditions (high light, intermittent light) and an enrichment of the FCP fractions in DD-DT in *P. tricornutum* and *Cyclotella* spp. has been observed in these light conditions (Lavaud *et al.* 2003; Beer *et al.* 2006). Interestingly, in parallel with the enrichment of FCP sub-complexes in DD-DT there is a decrease in FX. Whether this is due to some replacement of FX by DD molecules in the same protein or to a change in

the expression level of a special DD binding FCP(s) remains to be elucidated. Nevertheless, the recent identification of a specific DD-DT binding trimeric sub-complex (Guglielmi *et al.* 2005; Beer *et al.* 2006; Gundermann and Büchel in press) and the observation that the monomer composition of this sub-complex changes in parallel with the amount of DD-DT on one side and the proportion FX/Chl *c* on the other side argue for the second proposal (Owens and Wold 1986; Rhiel *et al.* 1997; Lavaud *et al.* 2003; Beer *et al.* 2006; Lepetit *et al.* 2007). Even if DD increased at the disfavour of both FX and Chl *c*, the decrease in both light-harvesting pigments remains relatively low, so do the decrease in the capacity for harvesting light (Lavaud *et al.* 2003). It has been recently reported that in diatoms the synthesis of pigments and especially of xanthophylls is driven both by cell division and endogenous control with a circadian regulation (Ragni and D'Alcala 2007). In particular, the DD pool shows an earlier and faster accumulation than the rest of the pigments. It is suggested to be due to an internal switch responding to the dark to light transition, so that the availability of a large pool of DD already before midday prepares the cells to a potentially stressful high irradiance exposure. This trigger appears to be active over a certain light intensity threshold. Hence, exogenous signals like night/day transitions and the irradiance probably play a role in phasing and modulating xanthophyll synthesis in nature for a better partition of the physiological regulation of photosynthesis over 24 h.

### The biosynthetic pathway of the xanthophylls

Because of the specific importance of the xanthophylls in the photosynthetic ability of diatoms, the properties of their biosynthetic pathway are described in the following chapter (see Fig. 3). More details on the biosynthetic pathways, including biochemical and genomic data, of the pigments of diatoms in general can be found in the review of Wilhelm *et al.* (2006). It has been recently found that the genes encoding homologues of most of the enzymes known to be involved in the biosynthesis of Chls and carotenoids in higher plants are present in the genome of *T. pseudonana* (Armbrust *et al.* 2004) (for a description of Chl synthesis in algae see Cahoon and Timko 2003). Still, the genes/proteins responsible for biosynthesis of the Chl *c* and those involved in the late steps of xanthophyll synthesis remain to be discovered.

Labelling kinetics of carotenoids in *Thalassiosira weissflogii* suggested that DD is a precursor of FX (Goericke and Welschmeyer 1992) (Fig. 3). This was corroborated by analyses of the pigment conversion kinetics in two other diatoms, *P. tricornutum* and *Cyclotella meneghiniana*, which also showed that zeaxanthin (ZX), antheraxanthin (AX) and VX are intermediates in the formation of DD and FX (Lohr and Wilhelm 1999, 2001). These three pigments are components of the XC in higher plants and brown algae which implies the conversion from VX to ZX via AX under a high light exposure. The hydroxylation of  $\beta$ -carotene into ZX, and not VX, is a pathway similar to the one existing in higher plants and brown algae. The significant accumulation of VX, AX and ZX has been observed in diatoms and related organisms having DD, and in which until recently the presence of the VX-AX-ZX cycle similar to the one of higher plants was unknown (Lohr and Wilhelm 1999). Hence, under some special light conditions (very high irradiance for several hours), not only the accumulation of these pigments occurs but also the operation of the corresponding XC. Indeed, the enzyme responsible for the de-epoxidation of DD into DT, the DD de-epoxidase (DDE), is also able to convert VX into AX and ZX with a similar efficiency (Jakob and Wilhelm 2001). Additionally, it has been recently found in the genomic data base of *P. tricornutum* the presence of two genes encoding two homologues of the VX de-epoxidase ('VDE-like', A. Gruber pers. comm.). It is still unclear if the provisory accumulation of ZX under these stressful light conditions is only an unavoidable conse-

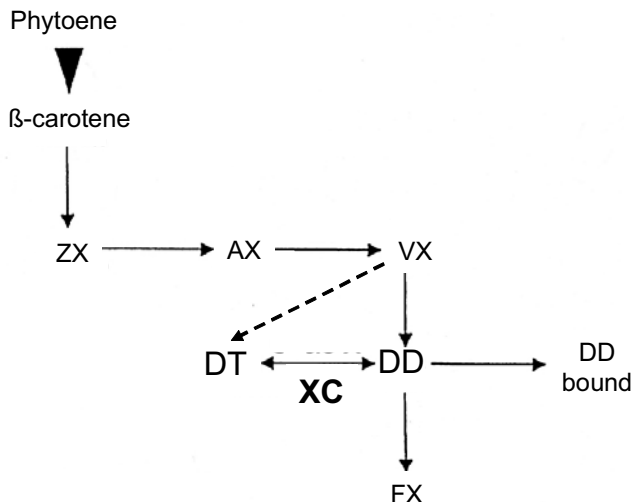

**Fig. 3 Simplified biosynthetic pathway of the carotenoids and xanthophylls in diatoms** (adapted from Lohr and Wilhelm 2001). The dashed line refers to the so-called *de novo* synthesis of DT. AX, antheraxanthin; DD, diadinoxanthin; DT, diatoxanthin; FX, fucoxanthin; VX, violaxanthin; XC, xanthophyll cycle, ZX, zeaxanthin. See the text for a full description.

quence of the properties of the DD and VX de-epoxidases or if it has a real physiological significance by increasing the photoprotective ability of the LHC antenna. ZX is involved in the photoprotection in organisms related to diatoms like the brown algae and the Crysiophyceae (Lichtlé *et al.* 1995; Lohr and Wilhelm 1999). Additionally, VX can be the direct precursor of DT under prolonged high light exposure thus resulting in *de novo* DT synthesis without the need for the DD intermediary (Lavaud *et al.* 2004) (**Fig. 3**). This has been shown by using dithiothreitol, an inhibitor of the DDE, in which presence the DT accumulation from DD is blocked in contrast to the *de novo* synthesis (Olaizola *et al.* 1994). The physiological role of these additional DT molecules is described later.

The DD pool is heterogeneous (**Fig. 3**). It is made of two distinct sub-pools with different roles. One of them has a very low turn-over (Goericke and Welschmeyer 1992) and is non-convertible into DT. Its size is usually 40-50% of the total (Lohr and Wilhelm 2001), but can reach more than 60% in some species (Lavaud *et al.* 2004). The size of this DD pool seems not to be influenced by the light growing conditions (Willemoës and Monas 1991). Especially, when the size of the total DD pool is doubled, the proportion of the non de-epoxidable pool remains constant (Lavaud *et al.* 2002a). By analogy with the VX in higher plants, this DD sub-pool is believed to be constitutive of the LHC antenna and to be involved, as well as FX (Pascal *et al.* 1998) in the structural stabilization of the pigment-protein complexes and possibly in the harvesting of light (Lavaud *et al.* 2003). In higher plants, the sub-pool of VX has about the same size and it cannot be de-epoxidized into ZX because it is not accessible to the de-epoxidase due to the macromolecular organization of the LHCs in the thylakoid membrane (Pfundel and Bilger 1994). The same reasons have been proposed in diatoms (Lavaud *et al.* 2003). The second half of the DD pool (50-60%) has a much higher turn-over (Goericke and Welschmeyer 1992) and shows two important roles. The first one is its involvement in the XC and conversion into DT. The exact localization of this pool is still under discussion but recent studies have shown that it is probably at the periphery of the LHC complex, hence accessible to the DDE, and bound by specific FCP monomers (Lavaud *et al.* 2003; Guglielmi *et al.* 2005; Beer *et al.* 2006; Lepetit *et al.* 2007). By analogy to higher plants (Havaux and Niyogi 1999; Johnson *et al.* 2007) it has also been proposed that in some species and under certain conditions, part of this sub-pool could be localized in the lipid matrix of the thylakoid

membrane or at the interface LHC antenna/lipid matrix where it could prevent the lipids from peroxidation during conditions of oxidative stress (like light stress exposure) and stabilize the thylakoid membrane structure (Lavaud *et al.* 2004; Schumann *et al.* 2007). The second major role of this DD sub-pool is to be the precursor of FX (Goericke and Welschmeyer 1992; Lohr and Wilhelm 1999, 2001). The regulation of the size of these two sub-pools as a function of light intensity is described later.

In the brown algae and the Crysiophyceae, both part of the Heterokontophytes, DD is still the precursor of FX but is not involved in the XC. Instead, the DD-DT cycle is replaced by the VX-AX-ZX cycle like in higher plants. For a reason which remains unknown, the brown algae have evolved towards the acquisition of the VX cycle (see later). In contrast, the Dinophyte group shows the DD-DT cycle but in some species the FX has been replaced by a specific pigment: the peridinin (see Mimuro and Akimoto 2003).

### The organization of the light-harvesting complex (LHC) antenna

Higher plants and green algae are the organisms whose supramolecular organization of the LHC antenna system has been most extensively studied, revealing a clear picture of the pigment and protein composition of LHC complexes, and the spatial distribution of these complexes as well as their dynamics (reviewed by Dekker and Boekema 2005). Additionally, X-ray crystallography has revealed the molecular structure of some LHCs of higher plants with near atomic resolution. Also, a review on the LHC composition of all groups of Chl *c*-containing algae, especially dinoflagellates for which the work is rather advanced, has been published recently (Macpherson and Hiller 2003). Comparable data are lacking for the diatom antenna system. Still the recent fine biochemical and spectroscopic works (Büchel 2003; Lavaud *et al.* 2003; Guglielmi *et al.* 2005; Papagianakis *et al.* 2005; Beer *et al.* 2006; Lepetit *et al.* 2007; Gundermann and Büchel in press; Nagao *et al.* in press; Szabo *et al.* in press; Veith and Büchel in press) coupled together with the newly available genomic information will help us to soon better understand the unique light harvesting capabilities in diatoms.

The LHC antenna system of diatoms is made of multimeric pigment-protein complexes called FCPs for 'Fucoxanthin Chlorophyll Proteins' which are intrinsic to the thylakoid membrane as in higher plants. As seen before, their pigmentation is drastically different compared to plants. The sequencing of some of the *fcp* genes in *P. tricornutum*, *O. sinensis* and *Cyclotella cryptica* showed some homology to the LHC of PS II (LHC II) of higher plants, placing these proteins into the same multigene family (Bhaya and Grossman 1993; Apt *et al.* 1994; Kroth-Pancic 1995; Eppard and Rhiel 1998). Six *fcp* genes have been first described in *P. tricornutum* and eight in both *S. costatum* and *C. cryptica* (Bhaya and Grossman 1993; Janssen *et al.* 2001). The sequence similarity between these diatom FCP polypeptides is high (77-99%) as well as with the sequences from FCPs of brown algae (60%) (Apt *et al.* 1995; de Martino *et al.* 2000; Green 2003). The recent efforts in sequencing two genomes of diatoms allowed to considerably increase the number of described *fcp*s genes and related genes: they are now believed to be between 20 and 30 (Armbrust *et al.* 2004), confirming the earlier assumption of 23 unique *fcp*s genes in *C. cryptica* (Eppard and Rhiel 2000). Four groups can be clearly distinguished so far (**Table 1**) (Eppard and Rhiel 1998; Eppard *et al.* 2000; Wilhelm *et al.* 2006). One group represents the major FCPs in diatoms, *fcp1-5* in *C. cryptica* and *fcpA-F* in *P. tricornutum* and *S. costatum* belong to these genes. FCP 1-3 and 5, as well as FCP C, D, E, were shown to compose the major part of the antenna system in *C. cryptica* and *P. tricornutum*, respectively (Beer *et al.* 2006; Lepetit *et al.* 2007). Nevertheless it is still unclear to which photosystem(s) the corresponding FCP complexes bind. The second group of *fcp* genes (found in *C.*

**Table 1** Description of the different Fucoxanthin Chlorophyll protein (FCP or 'LHCF') groups in the diatoms. (see the text for details)

FCP group	Cluster with	Description	Localisation (FCP sub-complexes)	Light regulation
I	FCPs of Heterokontophytes 'Major LHC antenna'	* <i>Cc</i> : FCP 1-3 (18 kDa), FCP 5 (19 kDa) * <i>Pt</i> : FCP C/D (18 kDa), FCP E (19 kDa)	* <i>Cc</i> : 'FCP a and b' * <i>Pt</i> : 'LHCF D and F' Bound to PS II and/or to PS I (?)	* <i>Cc</i> : Up LL
II	LHCa (LHC I) of red algae	* <i>Cc</i> : FCP 4 (18 kDa)	PS I minor antenna (?)	* <i>Cc</i> : Up LL
III	LI818 of green microalgae	* <i>Cc</i> : FCP 6/7 (19 kDa), FCP 12 (22 kDa) * <i>Pt</i> , <i>Tp</i> : 4 polypeptides	* <i>Cc</i> : in 'FCP a' only * <i>Pt</i> : in 'LHCF D' (?) Bound to PS II (?)	* <i>Cc</i> : Up HL * <i>Tp</i> : Up HL
IV	ELIPs of higher plants	* <i>Pt</i> , <i>Tp</i> : HLIPs 1/2, 1x SEP, 1x ELIP	Bound to PS II (?) and/or to PS I (?)	* <i>Pt</i> : Up HL

*Cc*, *Cyclotella cryptica*; ELIP, Early Light Induced Protein; HLIP, High Light Induced Protein; HL, High light intensity; LHC, Light-harvesting complex, LHC I, LHC of the PS I; LHCF, LHC containing fucoxanthin; LI818, Light-Induced 818 LHC polypeptide; LL, Low light intensity; *Pt*, *Phaeodactylum tricornutum*; PS II and I, Photosystem II and I; SEP, Stress Enhanced Protein; *Tp*, *Thalassiosira pseudonana*.

*cryptica* as *fcp4* and also in *T. pseudonana*, Eppard and Rhiel 1998; Armbrust *et al.* 2004) is closely related to *lhca* which encodes for the PS I LHC (LHC I) in red algae. This recent discovery is a good hint that possibly a specific 'minor LHC I' could exist in diatoms. Nevertheless, this question remains open so far (see below). The third group is related to a protein found in *C. reinhardtii* but not in higher plants: a light inducible member of the LHC superfamily, LI818. In *C. cryptica*, *fcp6*, 7 and 12 belong to this group (Eppard and Rhiel 2000). They are also present in the genome of *T. pseudonana* and *P. tricornutum* and up-regulated under high light (B. Green, pers. comm.). The last group refers to the ELIP family (Early Light Induced Proteins) which is also part of the LHC superfamily and is found in cyanobacteria as well as in higher plants (Adamska 2001). These proteins are especially overexpressed under high light stress; still their exact function remains unclear. Several genes encoding proteins of the ELIP family have been annotated in the genome of *T. pseudonana* and *P. tricornutum* (see **Table 1**). They are up-regulated under high light (S. Ng Chin Yue and Lavaud, unpublished data).

Generally, FCPs are smaller in size (18-22 kDa) compared to higher plant LHC, mainly due to shorter loops and termini (see **Table 1**). Using a monoclonal antibody raised against one of the FCPs of *P. tricornutum*, Friedman and Alberte (1987) observed a signal comprised between 17 and 21 kDa in several marine and freshwater diatom species. According to the special evolution of the diatom plastids, the addressing of the FCP proteins, which are encoded in the nucleus, to the plastid is peculiar since the polypeptides have to cross the four membranes surrounding the plastids (Grossman *et al.* 1990; Kroth 2002). Hence, FCPs have a bipartite pre-sequence allowing the import into the plastid following a two step process whereby the signal sequence is first removed leaving a typical chloroplast targeting domain ('transit' domain) that directs the FCP precursor to the thylakoid membrane (Lang and Kroth 1998; Gruber *et al.* 2007).

From the FCP sequence information, three membrane spanning helices were predicted, whereby homology to LHC of higher plants is mainly found in helices 1 and 3 (Green and Durnford 1996). The secondary structure of FCP complexes in *P. tricornutum* (Hiller *et al.* 1987; Eppard and Rhiel 1998; Eppard *et al.* 2000) has been confirmed to be similar to the one described in higher plants (Kuhlbrandt *et al.* 1994). Especially, binding sites of the Chl molecules are much conserved between Chl *a/c* and Chl *a/b* organisms (Green and Kuhlbrandt 1995; Paulsen 1995). Nevertheless, the localization of the xanthophylls, and especially of DD-DT, remains largely unknown. A first in depth examination conducted on a monomeric diatom FCP was published recently (Papagiannakis *et al.* 2005). It showed that the pigment stoichiometry of FCP in diatoms is 4:4:1 Chl *a*:FX:Chl *c*, the same as in FCPs of brown algae (de Martino *et al.* 1997). A preliminary structural model, based on both sequence comparison and spectroscopy allowed building a model for the pigment binding within a FCP protein (Wilhelm *et al.* 2006). It shows that the central crossed

helices 1 and 3 bind all Chls with Chl *c* located in close vicinity to Chl *a* due to the rapidity (100 fs) and efficiency (100%) of energy transfer between these two pigments (Papagiannakis *et al.* 2005). Two FX are arranged in the same way as lutein in the LHCI of higher plants, i. e. they are crossing each other by tight binding to the crossed helices 1 and 3. The same structure has been reported for the FCP of brown algae (Pascal *et al.* 1998). By analogy to the role of lutein in higher plants, these two FX could stabilize the FCP complex (Kuhlbrandt *et al.* 1994). The localization of the two other FX molecules is unclear and probably follows a situation different from higher plants for the lutein. Regarding the observation that the four molecules of FX are not equally efficient in transferring energy to Chl *a*, one being very efficient and another not, it has been proposed that one of the FX would be close to one of the four Chl *a*, similar as in higher plants, and the other FX would be located more at the periphery of the FCP far from the Chl *a* (Lavaud *et al.* 2003; Papagiannakis *et al.* 2005; Szabo *et al.* in press). An association between one FX and Chl *c* is also quite probable (Szabo *et al.* in press). For a more detailed description of the optical properties of FX and the energy transfer within algal antenna systems rich in carotenoids, see Mimuro and Akimoto (2003).

Despite recent works, biochemical information on the fine spatial organization of the FCP complexes remains scarce. Although two FCP sub-complexes have been observed to be more tightly bound to each photosystem (Friedman and Alberte 1984; Lavaud *et al.* 2003) (**Fig. 4**), no specific PS I or PS II antenna with specific pigments/polypeptides could be clearly found so far, unlike in higher plants (Owens and Wold 1986; Caron and Brown 1987; Berkaloff *et al.* 1990). Instead, a 'major' oligomeric FCP fraction is usually isolated (Lavaud *et al.* 2003; Lepetit *et al.* 2007) (**Fig. 4**) and some FCP polypeptides (FCP 2 and FCP 4) were recently shown to be associated with both photosystems in *Cyclotella cryptica* arguing for no distinct differentiation of PS I- and PS II-specific antenna (Brakemann *et al.* 2006). This major FCP fraction is equally able to transfer the light excitation energy to both photosystems (Owens 1986; Smith and Melis 1987). This situation has also been reported for some groups nearby to diatoms like the brown algae (de Martino *et al.* 2000) and a class of green microalgae rich in xanthophylls, the Prasinophyceae (Schmitt *et al.* 1993). Nevertheless, a putative LHCI antenna has been reported in Chl *a/c* organisms, the Xanthophyceae (Büchel and Wilhelm 1993) and the Cryptophytes (Bathke *et al.* 1999), and additionally *fcp* genes closely related to LCHI genes of red algae (*lhca*) have been found in the genomic databases. Also recently, pure PS II and PS I particles from two different species have been isolated together with possibly specific FCPs (Nagao *et al.* in press; Veith and Büchel in press). Nevertheless, the PS II and PS I complexes showed the same pigments in contrast to higher plants. Only differences in the amount of these pigments could be observed, confirming previous report (Lavaud *et al.* 2003) so that the absorption properties of the two photosystems

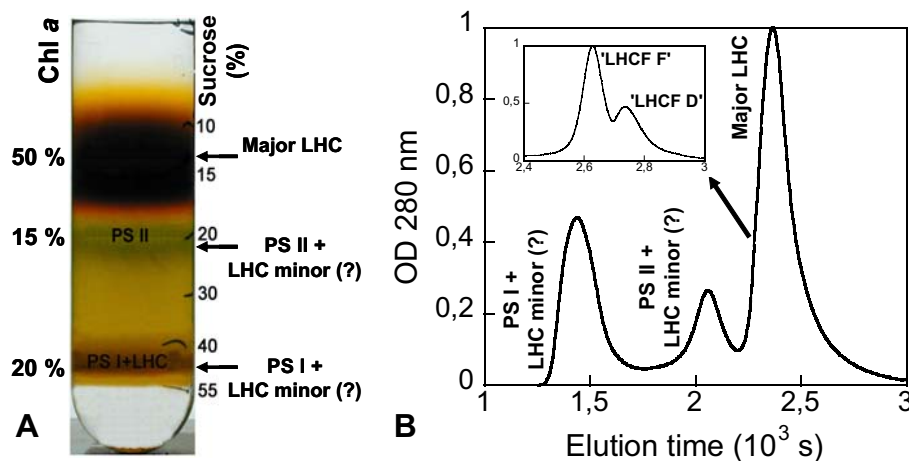

**Fig. 4 Isolation of the possible main complexes from the light-harvesting complex (LHC) antenna in cells of the diatom *P. tri-cornutum*.** (A) Sucrose gradient showing the three possible main LHC complexes ('?' means that the existence of the minor LHCs is still a question of debate) and their contribution in the total Chl *a* amount loaded on the gradient after treatment with a mild detergent (adapted from Lavaud *et al.* 2003). (B) Gel filtration profile of the same three LHC complexes after the same treatment (courtesy of G. Guglielmi). Inset: separation of the major LHC complex into two sub-complexes ('LHCF', see also **Table 1**) through a second gel filtration (adapted from Guglielmi *et al.* 2005). See the text for details.

are rather similar. To summarise, PS II has more FX and Chl *c* than PS I, DD/DT being equivalent to PS I or higher in PS II, and  $\beta$ -carotene being slightly higher in PS I (Berkaloff *et al.* 1990; Lavaud *et al.* 2003; Nagao *et al.* in press; Veith and Büchel in press). All in all, the questions of specific LHC II and LHC I antennas and/or of the sharing of a common antenna between the two photosystems remain open. Up to now only two distinguishable FCP polypeptides were isolated in *C. meneghiniana* and *P. tri-cornutum* (Büchel 2003; Lepetit *et al.* 2007). In *C. meneghiniana*, their oligomeric state differed: the 18 kDa proteins with some 19 kDa proteins assembled into trimers (like the LHCII in higher plants), whereas the 19 kDa subunits alone were arranged in stable higher oligomers of six to nine FCPs. This was not true for *P. tri-cornutum*, both 18 and 19 kDa polypeptides composing both trimers and higher oligomeric states (Lepetit *et al.* 2007). Interestingly, in the closely related brown algae, the FCP complexes have been shown to form high oligomeric structure of 120 to 380 kDa, according to the detergent and isolation procedure used (Guglielmi 1984; Katoh and Ehara 1990; Passaquet *et al.* 1991), which can be seen under electronic microscopy (Berkaloff *et al.* 1983; Katoh and Ehara 1990). Isolation of FCP macro-complexes from brown algae showed a multimeric discoid organisation of seven sub-units of 54 kDa each thought to be formed by three 18 kDa FCPs (Katoh and Ehara 1990). It would resemble the 440 kDa major FCP fraction isolated in *P. tri-cornutum* (Lepetit *et al.* 2007). The major FCP fraction usually isolated from *P. tri-cornutum* has been previously separated in two FCP complexes showing different pigment content: a major Chl *a/c*-FX fraction and a minor Chl *a/c* complex (Owens and Wold 1986). With the improvement of the isolation procedure, several FCP sub-complexes have been isolated from several species (*P. tri-cornutum* and *Cyclotella* spp.) and characterized (Büchel 2003; Guglielmi *et al.* 2005; Beer *et al.* 2006; Brakemann *et al.* 2006; Lepetit *et al.* 2007). In *P. tri-cornutum*, two FCP sub-fractions with different pigment contents co-exist (see inset **Fig. 4B**, **Table 1**). One fraction contains Chl *a/c* and FX but is nearly depleted in DD ('LHCF F') while the other fraction contains Chl *a*, FX and DD but is nearly depleted in Chl *c* ('LHCF D'). Interestingly, while the first one contains polypeptides in the range of FCPs, the second shows smaller polypeptides (10-15 kDa) in addition to FCPs. A similar DD enriched sub-fraction has been reported in *C. meneghiniana* (Beer *et al.* 2006), this complex shows a high degree of deoxygenation under high light exposure as previously observed in *P. tri-cornutum* for the highest level of FCP complex organisation (Lavaud *et al.* 2003). In both *P. tri-cornutum* and *C. meneghiniana* the identification of polypeptides composing the oligomeric FCP fractions has been possible. In *C. meneghiniana*, the oligomeric fraction (mainly made of 19 kDa polypeptides, sub-complex named 'FCP b') is most probably composed of FCP 5, while the trimeric fraction (mainly 18 kDa polypeptides, sub-complex named

'FCP a') enriched in DD is composed of subunits of FCP 1-3 and FCP6/7 which are up-regulated under high light exposure (Beer *et al.* 2006). In *P. tri-cornutum*, the 18 kDa polypeptide is encoded by the *fcpE* gene while the 19 kDa one corresponded to *fcpC* and *fcpD* genes, both 18 and 19 kDa polypeptides composing the two states of the antenna system (trimers and higher oligomers) (Lepetit *et al.* 2007) (**Table 1**). This observation stresses out the possibility that the organisation of the LHC antenna might be different from a diatom species to another. Clearly, a more in depth biochemical work is needed to clarify the organization of the FCP antenna system of diatoms; one of the major problem being our ability to separate the different FCP polypeptides because of their high similarity (Wilhelm *et al.* 2006; Lepetit *et al.* 2007).

### Fast regulation of the diatom photosynthesis in an underwater light fluctuating environment

The fast regulation of the light reactions in photosynthesis in fluctuating light has been recently reviewed (Kramer *et al.* 2004; Rascher and Nedbal 2006), especially for the microalgae (Grobbelaar 2006) but there are not so many works which studied the fine physiology of diatoms grown under a light regime reproducing the light fluctuations the cells may encounter in the field (see Litchman 2000; Fietz and Nicklisch 2002; Wagner *et al.* 2006 and references herein) surely for technical reasons. In recent outside mesocosm studies reproducing the mixing regime of shallow lakes and coastal areas, *S. costatum* has been shown to perfectly acclimate to different light fluctuation regimes (brought by different mixing depths and time scale of mixing) and its growth rate not to be affected (Patel *et al.* 2004, 2005), confirming early observation on another species, *Lauderia borealis* (Marra 1978). Recently it has been shown that the acclimation pattern of diatoms to a fluctuating light regime differs from those to steady high and low light (Fietz and Nicklisch 2002; van Leeuwe *et al.* 2005). For example, *Stephanodiscus neoastraea* acclimated to fluctuating light by doubling the number of PS II and halving its antenna size while the amount of Chls and carotenoids/xanthophylls remains unchanged. This strategy is totally different from the cyanobacteria it was compared with, bringing some physiological insights to the difference in growth rate between diatoms and cyanobacteria (Litchman 2000; Mitrovic *et al.* 2003) since the cyanobacteria showed a depression of their photosynthesis under fluctuating light (Fietz and Nicklisch 2002). In another study with another species (*Chaetoceros brevis*), the cells acclimated to the average light intensity rather than to the maximum irradiance (van Leeuwe *et al.* 2005), allowing the cells to perform high rate of photosynthesis during the low irradiance periods while protecting against the excess of light absorbed during the high irradiance periods via different means (see the following chapters). Nevertheless, the acclimation process to

fluctuating light is likely to be species dependent since *S. costatum* (Kromkamp and Limbeek 1993) and *T. weissflogii* (van de Poll *et al.* 2007) acclimate to the highest irradiance encountered during the fluctuations, especially by increasing the amount of DD-DT (van de Poll *et al.* 2007). Obviously, the acclimation strategy depends on the flexibility of the photosynthetic regulation and on the genomic plasticity of the species as recently demonstrated (Lavaud *et al.* 2007; van de Poll *et al.* 2007). Finally, in a very complete investigation, Wilhelm and co-workers (Wagner *et al.* 2006; Jakob *et al.* 2007) also pointed out the different photoacclimatory strategies of *P. tricornutum* in comparison to a green microalga. It has been demonstrated that the diatom has a much higher conversion efficiency of photosynthetic energy into biomass in a fluctuating light regime than the green microalga. This dissimilarity is caused by the nature of the processes, as well as their amplitude and kinetics, used to dissipate the excess of energy during the high light exposure periods.

The short-term photoacclimative processes can be defined as the processes which prevent and/or limit the photodamage of PS II, but also of the stromal components (Luis *et al.* 2006), and subsequent decrease in the photosynthetic ability (i.e. photoinhibition) under an excess light exposure, typically at mid-day. These rapid 'physical' mechanisms can be switched on in few tens of seconds during a sudden increase in incident light intensity, and thus do not involve gene regulation. The short-term photoacclimative processes were also shown to be important in photoprotecting the photosynthetic machinery over prolonged high light stress (1 h) (Lavaud 2007). They include the processes for dissipating the excess energy within the PS II – the non-photochemical fluorescence quenching (NPQ), the state-transitions, and the PS II electron cycle – which avoid the overexcitation of the photosynthetic apparatus and in first place of the PS II reaction centre. The fast D1 protein repair cycle can also be included into the category of these so-called 'photoprotective mechanisms' (Andersson and Aro 2001; Stroch *et al.* 2004). Outside of the processes taking place at the PS II, there are a number of others, which have also been shown to play a role in photoprotection in algae, and which are more or less fast reacting mechanisms such as the scavenging of oxygen (O<sub>2</sub>) radicals (reactive oxygen species, ROS) and the alternative electron pathways like the electron cycle around PS I, the Mehler reaction (also called water-water cycle), the chlororespiration and photorespiration and the reduction of nitrate (see Niyogi 2000; Ort and Baker 2002; Miyake and Osada 2003; Raven and Geider 2003). Nevertheless, the data available on these processes in diatoms are very scarce (reviewed in Wilhelm *et al.* 2006) even if the photorespiration and reduction of nitrate start to be quite well understood (Parker and Armbrust 2005; Allen *et al.* 2006). The PS I electron cycle has been measured in *P. tricornutum* (Caron *et al.* 1987), the Mehler reaction in *P. tricornutum* (Geel *et al.* 1997) and in *Cylindrotheca fusiformis* (Claquin *et al.* 2004), the chlororespiration in *P. tricornutum* (Jakob *et al.* 1999; Lavaud *et al.* 2002c), and enzymatic activity linked to ROS scavenging in several species (Rijstenbil 2001, 2002; Sigaud-Kutner *et al.* 2002; Rijstenbil 2005; Wolfe-Simon *et al.* 2006). So far, the most extensively studied process for short-term photoacclimation in diatoms is the NPQ which is partially controlled by a very fast conversion of xanthophylls. This pigment conversion has been named 'xanthophyll cycle' (XC). NPQ is believed to be the most important rapid photoprotective process in diatoms even though the PS II electron cycle has been shown to be the first line of defence against an excess light exposure (Lavaud *et al.* 2002c, 2007). Finally, in contrast to higher plants, there are no experimental evidence for state-transitions in diatoms, as well as in the close related brown algae (Owens 1986; Smith and Melis 1987).

## The xanthophyll cycle, XC

The XC consists in the enzymatic de-epoxidation/epoxidation of carotenoid xanthophylls as a function of the incident light intensity. They are two groups of organisms which can be defined regarding the pigments involved in the XC (Larkum 2003). A first group shows as the main XC the two step de-epoxidation of VX into ZX via AX. This first group involves: the higher plants, the green algae, some Heterokontophytes (brown algae, Eustigmatophyceae, Crysiophyceae) and some red algae species (Raven and Geider 2003). A second group shows as the main XC the one step de-epoxidation of DD into DT, DT showing the same degree of de-epoxidation than its analogous ZX. This second group involves: some heterokontophytes (the diatoms and the Xanthophyceae), the Haptophytes, the Dinophytes and the Raphidophytes. In a third group of the phyla in which there is no XC but an accumulation of ZX directly from  $\beta$ -carotene or lutein (for the red algae, Schubert *et al.* 2006) under high light exposure: the cyanobacteria, the Prochlorophytes, the red algae, the Glaucosystophytes, the Cryptophytes and some species of green algae. Within the first group, some Prasinophyceae (a group of green microalgae) have been shown to be unable to convert VX further than AX (Goss *et al.* 1998) and some green macroalgae have no XC (Raven and Geider 2003). Also for the higher plants, a second XC, which is not always minor, has been reported in several plant species (as well as in the green microalga *Chlamydomonas*) involving the de-epoxidation of lutein into lutein-epoxide under certain circumstances like prolonged high light stress (Garcia-Plazaola *et al.* 2007). Additionally, in the green macroalga *Caulerpa*, a secondary XC involving the conversion of siphonaxanthin into siphonein has been reported (Raniello *et al.* 2006). Within the first and second group, there are also some phyla showing another second XC. Indeed, some Heterokontophytes (the diatoms, the Xanthophyceae), Haptophytes and Dinophytes show the VX-AX-ZX cycle under prolonged high light stress (Lohr and Wilhelm 1999) (see before). Nevertheless, this cycle in comparison to the DD-DT main cycle is minor and it is still unclear if the provisory accumulation of ZX under these stressful light conditions is only an unavoidable consequence of the properties of the XC, or if it has a real physiological significance by increasing the photoprotective ability of the LHC antenna system. Interestingly, for an unknown reason, among the Heterokontophytes, some very close phyla evolved towards the VX-AX-ZX as the main XC (the brown algae) while others (like the diatoms) evolved towards the DD-DT cycle.

The regulation and operation of the XC have been described in details earlier, especially for the VX-AX-ZX cycle (for recent reviews see Eskling *et al.* 2001; Latowski *et al.* 2004). The de-epoxidation/epoxidation events are ensured by two enzymes, a VX de-epoxidase (VDE) and a ZX epoxidase (ZEP) which are part of the few (in contrast to animals) lipocalin proteins known in plants. VDE is located on the lumen side and can bind/unbind to the thylakoid membrane as a function of the luminal pH, its optimal pH activity being around 5-6. ZEP is localised on the stroma side; its pH optimum is 7.5. In addition, VDE needs the acid form of ascorbate as a co-factor and ZEP the NADPH, H<sup>+</sup> and oxygen (O<sub>2</sub>). The operation of the XC results in the competition of the activity of these two enzymes as a function of the built-up of the transthylakoid proton gradient (which is driven by the irradiance-dependent photosynthetic electron transport rate) and subsequent change in luminal and stromal pH. In summary, when the irradiance is moderate to high, the luminal pH drops down to values between 4.5-6.5 (Kramer *et al.* 1999). This acidification 'activates' VDE which binds to some special lipids of the thylakoid membrane (the monogalactosyldiacylglycerol, MGDG) and enters in contact with the free or LHC-bound VX which is de-epoxidised into AX and ZX. The half-time for this process is about 60 s. When the light intensity decreases to darkness, the de-epoxidation becomes weaker and finally stops, while



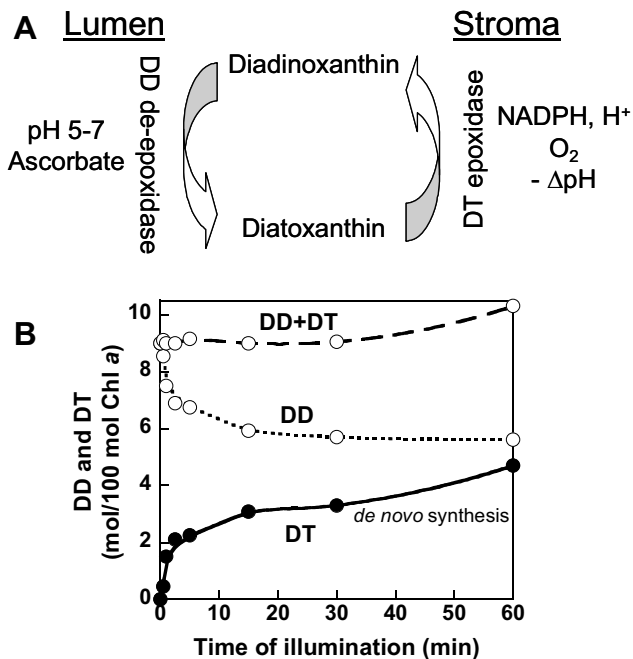

**Fig. 5** The xanthophyll cycle (XC) in diatoms. **(A)** Simplified scheme of the XC regulation (adapted from Wilhelm *et al.* 2006). Co-factor requirement for the enzymes is shown as well as the pH optimum.  $-\Delta\text{pH}$  means that the DT epoxidase is inhibited by the high stromal pH under high light exposure. See the text for a full description. **(B)** Kinetics of the DD de-epoxidation into DT in cells of the diatom *P. tricornutum* exposed to high light (here  $2000 \mu\text{mol photons.m}^{-2}.\text{s}^{-1}$ ) (adapted from Lavaud *et al.* 2004). ‘*de novo* synthesis’ refers to the DT synthesis arising directly from the DD precursor without no further DD de-epoxidation (DT increases, DD remains stable). Chl *a*, chlorophyll *a*; DD, diadinoxanthin; DT, diatoxanthin.

the inverse epoxidation reaction, which is ten times slower, becomes dominant (note that ZEP is also active under high light). Hence, the accumulation of the photoprotective de-epoxidised xanthophylls ZX and DT depends on the activity of the two enzymes which indirectly depends (via the change in pH and availability of the co-factors) on the light intensity. There is a series of recent molecular works which have been conducted in *Arabidopsis* and *Chlamydomonas* to better understand the regulation of VDE/ZEP and the role of ascorbate (see Jung and Niyogi (2006) for a review).

In the organisms displaying the DD-DT cycle, a similar mechanism has been described with some special features (Wilhelm *et al.* 2006) (**Fig. 5**). Most of these works have been conducted in diatoms where the XC parameters (the rate constant, the extent, the kinetics of de-epoxidation, etc.) are species-dependent (Lavaud *et al.* 2004). In contrast to VDE, DDE pH optimum is shifted towards higher pH and is even active at pH values about 7 (Jakob and Wilhelm 2001). Consequently, DD de-epoxidation can already be triggered by a weak lumen acidification induced by, for example, chlororespiration (Jakob *et al.* 1999). It also means that the DD de-epoxidation already occurs for lower light intensities and shorter illumination times than the VX de-epoxidation. Additionally, a recent study (Grouneva *et al.* 2006) showed that DDE requires much lower ascorbate concentration than VDE to be fully effective. Finally, DDE requires a lower concentration of MGDG to drive efficient de-epoxidation meaning that higher DD amounts can be converted under high light (Goss *et al.* 2005). Regarding the analogue of ZEP, the DEP (DT epoxidase) also shows an interesting characteristic: it is inactivated under an excess light exposure, which completely switches the equilibrium of the XC operation towards DT accumulation (Goss *et al.* 2006). This feature is believed to be due to a shortage in the co-factor NADPH,  $\text{H}^+$  under high light exposure. All together these special features of the DD-DT XC explain

very well the surprising efficiency and rapidity of accumulation of DT in large amounts (Lavaud *et al.* 2002a, 2004) (**Fig. 5B**).

### The non-photochemical Chl fluorescence quenching, NPQ

When Chl *a* molecules of the LHC antenna absorb light, they enter a singlet-state excitation  $^1\text{Chl}^*$  which energy is deactivated following several pathways (Müller *et al.* 2001). Most of the excitation energy is used to drive photochemistry, through charge separation within the reaction centre of photosystems, with some associated leaks: reemission of the energy via chlorophyll fluorescence and heat. There is nevertheless a non negligible part which can be dissipated through the ‘triplet valve’, thereby forming triplet-state excitation:  $\text{Chl} + \text{light} \rightarrow ^1\text{Chl}^* \rightarrow ^3\text{Chl}^*$  (Müller *et al.* 2001). This pathway depends on the lifetime of  $^1\text{Chl}^*$  which itself depends on the other deactivation pathways. When the light absorbed is in excess (i.e. under a high light exposure) and the ability of the photosynthetic machinery to use the excitation energy via photochemistry is at its maximum, the yield for Chl fluorescence increases and the probability of  $^3\text{Chl}^*$  formation increases. This situation is critical since  $^3\text{Chl}^*$  can react with  $\text{O}_2$  within the PS II reaction centre, generating reactive  $\text{O}_2$  species (ROS) such as singlet  $^1\text{O}_2^*$  which are very harmful for proteins, pigments and lipids and lead to a decrease in the rate of photosynthesis (i. e. photoinhibition). Photosynthetic organisms are able to maintain a low steady-state of  $^3\text{Chl}^*$  generation through several rapid ‘photoprotective’ mechanisms which help to minimize the production of ROS. NPQ is believed to be the most important of these processes and the carotenoid xanthophylls play a central role in NPQ, especially via the XC (see the previous chapter). Carotenoid xanthophylls (including  $\beta$ -carotene, Lichtenthaler 2007) are able to directly scavenge  $^3\text{Chl}^*$  (Müller *et al.* 2001; Larkum 2003):  $^3\text{Chl}^* + \text{car} \rightarrow \text{Chl} + ^3\text{car}^*$ . Additionally, they are strong anti-oxidants known to scavenge  $^1\text{O}_2^*$  (Galitano *et al.* 2007):  $^3\text{Chl}^* + \text{O}_2 \rightarrow ^1\text{O}_2^* + \text{car} \rightarrow \text{O}_2 + ^3\text{car}^*$ , thereby preventing the PS II D1 protein damage (Andersson and Aro 2001) and the lipid peroxidation (Havaux and Niyogi 1999). In both cases,  $^3\text{car}^*$  decay by various mechanisms releasing heat, and consequently decreasing the quantum yield of Chl fluorescence emission (‘quenching’). The ability of de-epoxidised xanthophylls, ZX and DT, to quench the excited states of Chl has been proven (Frank *et al.* 1994, 1996), especially in the framework of the NPQ mechanism (Frank *et al.* 2000; Holt *et al.* 2005; Gundermann and Büchel in press).

The NPQ process takes place in the LHCII and its role is to dissipate as heat or reallocate part of the excitation energy before it reaches the reaction centre during a light exposure which exceeds the ability of the photosynthetic machinery to use all the energy for photochemistry (**Fig. 6A**). Consequently, NPQ reduces the lifetime of  $^1\text{Chl}^*$  and in the mean time, the quantum yield of Chl fluorescence. In higher plants and green algae, NPQ can be divided into three components (Müller *et al.* 2001): qE, the energy-dependent quenching which is regulated by the built-up of a transthylakoid  $\Delta\text{pH}$  and the operation of the XC (see the previous chapter); qT, the state-transition quenching which allows reallocation of part of the energy absorbed from the PS II to the PS I; qI, the photoinhibitory quenching. Here, we will focus on the qE component (there is no qT in diatoms (Owens 1986), and qI has never been investigated in diatoms). qE has been investigated up to the molecular range, especially in higher plants and green microalgae (Pascal *et al.* 2005; Standfuss *et al.* 2005; Cogdell 2006), far less in other eukaryotic algae and cyanobacteria. The first correlation between qE and the accumulation of de-epoxidised xanthophylls under high light has been observed in higher plants and green microalgae. Later it has been reported in diatoms and dinoflagellates (Sakshaug *et al.* 1987; Mortain-Bertrand and Falkowski 1989; Demers *et al.* 1991; Ting and Owens 1993; Arsalane *et al.* 1994; Olai-

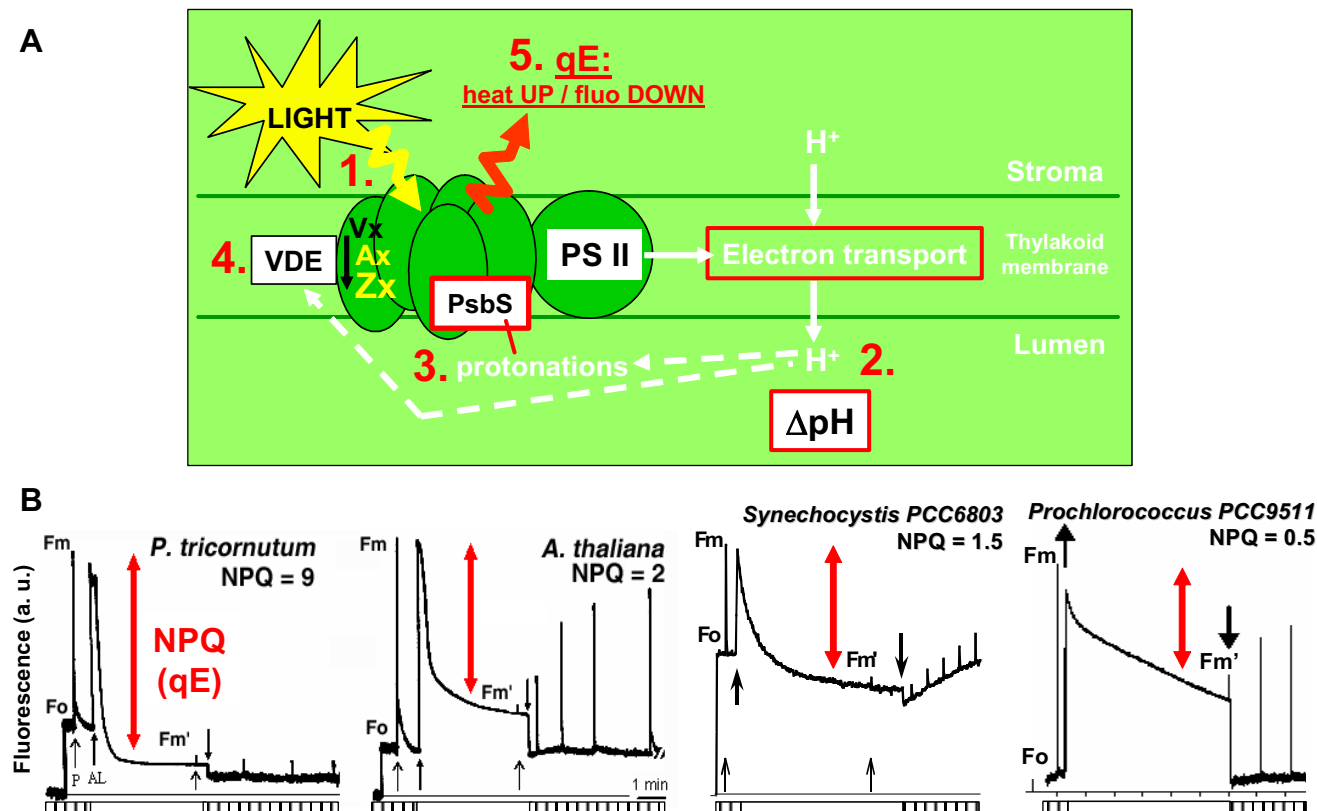

**Fig. 6 The non-photochemical chlorophyll fluorescence quenching (NPQ, qE).** (A) Simplified model of the qE mechanism in higher plants (modified from an original scheme from K. K. Niyogi). The numbering refers to the sequence of the qE process steps. AX, antheraxanthin; PS II, photosystem II; VDE, violaxanthin de-epoxidase; VX, violaxanthin; ZX, zeaxanthin;  $\Delta pH$ , transthylakoid proton gradient. See the text for a full description. (B) Characteristic chlorophyll fluorescence signals as measured with a PAM fluorometer in cells of the diatom *P. tricornutum*, leaves of the higher plant *Arabidopsis thaliana*, cells of the cyanobacterium *Synechocystis* PCC6803, and cells of the Prochlorophyte *Prochlorococcus* PCC9511 (adapted from Ruban *et al.* 2004; Cadoret *et al.* 2004; Bailey *et al.* 2005).  $F_0$ , minimum fluorescence level in the dark (detector beam only),  $F_m$ , maximum fluorescence level in the dark,  $F_m'$ , maximum fluorescence level at light. NPQ (qE) =  $(F_m - F_m')/F_m'$ . AL, actinic light of 2000  $\mu\text{mol photons}\cdot\text{m}^{-2}\cdot\text{s}^{-1}$  (5 min duration, arrows up/down: switch on/off); P, over-saturating pulses (600 ms duration, thin arrows: pulse fire). Bars: dashed, detector beam only; white; detector beam+AL on. The time scale is given on the *A. thaliana* trace.

zola and Yamamoto 1994), Cryophyceae (Lichtlé *et al.* 1995; Casper-Lindley and Bjorkman 1998), red algae (Ritz *et al.* 1999), and more recently in cyanobacteria and Prochlorophytes (Bailey *et al.* 2005), and picoplanktonic green algae (Dimier *et al.* 2007) (see also Fig. 6B). A linear relationship between the operation of the XC, and the subsequent accumulation of ZX-AX and DT, the development of qE and the quenching of Chl fluorescence has been described in details earlier (Gilmore and Yamamoto 1991; Lavaud *et al.* 2002a). The model for the qE mechanism is rather well understood in higher plants and green microalgae (Horton *et al.* 2005; Jung and Niyogi 2006) (Fig. 6A). In summary, it implies a feed-back reaction from the linear electron transport via the built-up of a transthylakoid  $\Delta pH$  and subsequent acidification of the lumen of the thylakoid: the higher the light intensity, the higher the electron transport and coupled translocation of protons, the higher the accumulation of protons into the lumen. This acidification has two consequences: the protonation of specific sites of a special LHC protein identified as PsbS in higher plants (still unknown in diatoms) and the activation of the VDE for synthesis of ZX. The exact role of PsbS remains unclear although the actual common view gives it a role in sensing changes in the lumen acidification (Niyogi *et al.* 2005). Both protonated PsbS and the presence of ZX are thought to act together as the trigger of the qE process (even though in higher plants, protonation of the LHC proteins without any synthesis of ZX is sufficient to generate a basal NPQ; Niyogi *et al.* 1998). The first one promotes and transduces conformational changes within the LHC system ('aggregations') which bring closer together pigments and especially Chl molecules. The second one acts as an 'allo-

teric regulator' by amplifying the conformational changes within the LHC antenna. Hence both PsbS and ZX promote and stabilize the switching of the whole LHC antenna into a dissipative mode (in addition to the light-harvesting mode) where excess excitation energy is converted into heat meanwhile Chl fluorescence is quenched (Holt *et al.* 2005; Pascal *et al.* 2005). Nevertheless, it remains unclear how the excess energy is converted into heat and dissipated: a fully elaborated thermodynamic model linking both the NPQ mechanism and the physical process of heat dissipation is still lacking.

The other group in which the qE mechanism and its relationship with the XC have been investigated in details are the diatoms (Ting and Owens 1993; Arsalane *et al.* 1994; Olaizola *et al.* 1994; Lavaud *et al.* 2002a). The major difference between the diatom qE and the plant qE is the amplitude of the phenomenon: qE can be up to 4-5 times in diatoms than in plants (Lavaud *et al.* 2002a; Ruban *et al.* 2004) (Fig. 6B) making it the most important rapid photo-protective process in diatoms. Indeed, it can account for up to 90% energy dissipation under over-saturating light conditions (Lavaud *et al.* 2002a). Other differences have been listed earlier in details (Wilhelm *et al.* 2006). They include a different LHC organization (Büchel 2003; Guglielmi *et al.* 2005; Lepetit *et al.* 2007) and especially the absence of important LHC proteins involved in NPQ in higher plants like PsbS and CP26-CP29 (Armbrust *et al.* 2004), a different localisation of the xanthophylls within the LHC (Lavaud *et al.* 2003; Beer *et al.* 2006), a capacity for accumulating large amounts of xanthophylls (Wilhelm 1990; Lavaud *et al.* 2002a) especially via *de novo* synthesis of DT as a function of irradiance (Lavaud *et al.* 2004) and a different composi-

tion and regulation of the XC (see the previous section). Additionally, qE appears to be more tightly associated with the XC and the accumulation of DT than in plants with ZX (Lavaud *et al.* 2002a, 2004) so that both the transthylakoid  $\Delta$ pH and XC have a strong role in finely regulating qE (Lavaud *et al.* 2002b; Ruban *et al.* 2004; Goss *et al.* 2006; Lavaud and Kroth 2006). Especially, it has been shown how the  $\Delta$ pH can modulate the capacity of specific FCP complexes in quenching fluorescence via a tight, not fully understood, relationship with the DT synthesis and the aggregation of FCP complexes (Lavaud and Kroth 2006; Gundermann and Büchel in press). The fine tuning of qE relative to light-dependent photochemical activity can be very different in diatoms in comparison with higher plants: some species are able to keep qE low, up to nearly half-reduction of the photosynthetic machinery (Ruban *et al.* 2004; Lavaud *et al.* 2007). Hence, in diatoms in comparison to their green counterparts, there is a relative independence of the PS II redox-state from the proton-motive electron transfer and subsequently qE. It is believed that this property arises from the high amplitude of a cyclic electron transport within PS II (Lavaud *et al.* 2002c; Onno Feikema *et al.* 2006; Lavaud *et al.* 2007) and/or the capacity to modulate the PS II electron turnover rates as a function of the irradiance (Behrenfeld *et al.* 1998). Even though part of the qE process in diatoms remains to be elucidated, recent advances allowed building a first mechanistic model (see Goss *et al.* 2006; Lavaud and Kroth 2006). All together, these differences in the regulatory components and mechanistic aspects of the qE process in diatoms in comparison with the green organisms have been suggested to ensure more flexibility and thus quicker response to the large light intensity fluctuations that diatoms may encounter in their natural habitat. This has been confirmed by the fact that diatoms show a higher qE/XC in a fluctuating light regime in comparison to the green algae (Wagner *et al.* 2006), the Prasinophyceae (van Leeuwe *et al.* 2005) and the Coccolitophores (van de Poll *et al.* 2007).

### High light and ultra-violet (UV) radiation regulation of the XC and NPQ

In diatoms, DT *de novo* synthesis under prolonged high light stress (Fig. 5B) allows the cells to increase their capacity for photoprotection and especially qE (Olaizola *et al.* 1994; Kashino and Kudoh 2003). This ability is species-dependent as well as the efficiency of these additional DT molecules in participating to qE (Lavaud *et al.* 2004). This feature is supported by the following facts (Lavaud *et al.* 2002a, 2004): (1) the DT *de novo* synthesis pathway is triggered when maximal DD de-epoxidation is reached, (2) its rate is irradiance-dependent, (3) DT *de novo* synthesis is no longer observed when the initial DD pool size is increased, (4) its starting time point (between 15 to 45 min at full sunlight: 2000  $\mu\text{mol photons.m}^{-2}.\text{s}^{-1}$ ) as well as its rate depend on the species (a factor two difference from a species to another). For example, the rate is similar for *P. tricornutum* and *T. weissflogii* but it starts earlier for the second since the size of the convertible DD pool is nearly 20% less. Since the *de novo* synthesis is irradiance-dependent, it could very well be the starting point for the dramatic increase in DD-DT observed during prolonged acclimation to high light. Indeed, acclimation of the cells to high light by increasing their DD-DT amount enhances their ability to rapidly respond to a further increase in irradiance in comparison to low light acclimated cells (Willemoës and Monas 1991; Casper-Lindley and Bjorkman 1998; Mouget *et al.* 1999; Perkins *et al.* 2006). Hence, the amount of DD per cell can be multiplied by a factor of 5 with increasing irradiance (Rhiel *et al.* 1997; Mouget *et al.* 1999; Anning *et al.* 2000; van de Poll *et al.* 2006). Such increase has also been reported from field measurements with a clear increase in DD-DT in the first meters of the water column (Olaizola *et al.* 1992; Brunet *et al.* 1993; Eisner *et al.* 2003; Fujiki *et al.* 2003). The additional DD can be converted into

DT (up to 50%, van de poll *et al.* 2006) so that over a certain irradiance (about 200  $\mu\text{mol photons.m}^{-2}.\text{s}^{-1}$ ), the constitutive de-epoxidation of DD competes with the synthesis of FX (Willemoës and Monas 1991; Goericke and Welschmeyer 1992; Mouget *et al.* 1999). Nevertheless, not all the additional DT, also arising from the *de novo* synthesis, molecules are involved in NPQ (Casper-Lindley and Bjorkman 1998; Lavaud *et al.* 2004; Schumann *et al.* 2007). It has been proposed that part of the newly synthesised DD-DT pool could have two functions regarding its localisation. The additional molecules which remain bound to the LHC antenna without participating to the NPQ could serve as a reservoir for the synthesis of FX under a subsequent low/darkness light period (Anning *et al.* 2000; Schumann *et al.* 2007). Therefore, unlike in the higher plants, diatoms can utilize part of the photoprotective XC pigments DD-DT synthesised from VX, which accumulate under high light conditions, for the formation of the major light-harvesting xanthophyll FX in subsequent low light (Lohr and Wilhelm 1999). Hence, by increasing their photoprotection ability through DD-DT synthesis under prolonged high light conditions, the diatoms simultaneously built the pool of precursor pigments necessary for FX synthesis during the next low light condition period. Such flexibility is highly appreciable for living in an aquatic environment where the light availability is fluctuating, especially in chronically low-light environment that is punctuated by brief exposure to high light as in estuaries or during lake spring blooms in temperate regions. Additionally, part of the DD-DT pool is located in the lipid matrix of the thylakoid membrane and was suggested to prevent the lipid peroxidation as in higher plants (Lavaud *et al.* 2004; Schumann *et al.* 2007). In *D. brightwellii*, only a small increase in lipid peroxidation has been observed after a several hour exposure to 400  $\mu\text{mol photons.m}^{-2}.\text{s}^{-1}$ , and there was no parallel increase in the activity of antioxidant enzymes (Rijstenbil 2001) well arguing for a possible role of DT in prevention of lipid peroxidation (likely together with  $\alpha$ -tocopherol as in higher plants; Lichtenthaler 2007). The increase in the DD-DT pool size with irradiance is related to the synthesis of new FCPs (Beer *et al.* 2006). In that framework, the work of Rhiel and co-workers in *C. cryptica* is very informative since it is the first and only series of rather complete investigation on the *fcp* gene expression as a function of light in the same species (Table 1) (Rhiel *et al.* 1997; Oeltjen *et al.* 2002, 2004). They especially showed that the expression of *fcp6*, 7 and 12 increases under high light. These three genes were additionally showed to form a cluster having some similarities with a light induced member of the LHC family, LI818, in *C. reinhardtii* (Eppard *et al.* 2000). These genes are also present in the genome of *T. pseudonana* (Armbrust *et al.* 2004) and *P. tricornutum*. Noteworthy, the proportion of FCP 6/7 monomers increases with high light in parallel with the amount of DD, the ratio of de-epoxidation into DT and the ability of the FCP sub-complex containing these polypeptides to quench fluorescence (Beer *et al.* 2006; Gundermann and Büchel in press). These data strongly argue for the existence of a specific FCP sub-complex, and possibly specific polypeptide(s) (Lepetit *et al.* 2007; Gundermann and Büchel in press), involved in NPQ as suggested earlier (Lavaud *et al.* 2003; Guglielmi *et al.* 2005).

In the aquatic field, an increase in the incident light intensity is always accompanied by an increase in UV radiation as the cells are swept upward to the surface. Under UV exposure, the pool size of DD and/or the ratio DD/Chl *a* have often been reported to increase in both pelagic and benthic diatoms, isolated and natural populations (Buma *et al.* 1996; Goss *et al.* 1999; Wulff *et al.* 2000; Zudaire and Roy 2001; Rech *et al.* 2005). Concerning the functioning of the XC and the amount of DT, the effect of UV radiation is very unclear. Indeed, some works reported a stimulation of the XC by UV, while others reported no effect or even an inhibition (or 'reversion'). For example, the XC has been shown to be stimulated in *P. tricornutum* by UV radiation (Goss *et al.* 1999), while other authors concluded in the

same species for an inhibition/reversion (Mewes and Richter 2002). And even if the works concluding for a stimulation of DD de-epoxidation used UV treatments which are closer to the radiation found in nature, there are examples of both effects, stimulation (Döhler and Hagmeier 1997) and inhibition/reversion (Rijstenbil 2005), from field experiments. The authors who measured NPQ in parallel to the XC operation all conclude that the change in NPQ is linked to the variation (increase or decrease) in the amount of DT (Goss *et al.* 1999; Mewes and Richter 2002; Rech *et al.* 2005; Rijstenbil 2005). Clearly in some species, the stimulation of the DD de-epoxidation into DT leads to a higher NPQ and consequently photoprotection while it is the opposite in others (Rech *et al.* 2005). The UV effect on the XC is dependent on the species (Buma *et al.* 1996; Lohmann *et al.* 1998; Rijstenbil 2003), the duration of the UV exposure (Zudaire and Roy 2001) and the relationship with other photoprotective processes such as production of UV-absorbing molecules (Zudaire and Roy 2001) and ROS scavenging systems (Rijstenbil 2005). In higher plants and green algae, there is no ambiguity: the VDE and consequently the XC are effectively directly inhibited by UV radiation (Goss *et al.* 1999). Compiling the data from the two studies which had a closer look at the operation of the XC under UV in diatoms (Goss *et al.* 1999; Mewes and Richter 2002), it appears that the situation is complicated by the fact that the benefit or harmful effect is not direct like in plants. Indeed, UV radiation has been suggested to indirectly act on initiators and/or co-factors of the XC: enhancing the transthylakoid  $\Delta pH$  by inhibiting both ATP synthase and Rubisco activities, enhancing ascorbate availability by increasing the membrane permeability, which could also negatively affect the transthylakoid  $\Delta pH$ , and this on both the DDE and the DEP, thus disturbing the equilibrium between opposite enzymatic reactions. Obviously, the effect of UV on the mechanism itself of the XC is complex and very dependent on the light treatments used, and would need further investigations to draw a definitive conclusion.

### The photosystem II electron cycle, PSII CET

The regulation of photosynthesis during fast and large changes in irradiance is not limited to the XC and NPQ. Indeed,

in diatoms an electron cycle within PS II exists (PS II CET for cyclic electron transfer; Onno Feikema *et al.* 2006) (Fig. 7) which has been described only recently and also participates in the photoprotection (Lavaud *et al.* 2002c; Onno Feikema *et al.* 2006; Lavaud *et al.* 2007). The PSII CET has been first reported in green microalgae and later in higher plants and cyanobacteria (Falkowski and Kolber 1986; Nebdal *et al.* 1992; Barber and de las Rivas 1993; Prasil *et al.* 1996; Whimmarsh and Pakrasi 1996). It avoids the over-saturation of the electron carriers after the PS II (plastoquinones, PQ). It also enters in competition with the oxidation of water and the subsequent  $O_2$  evolution (Geel *et al.* 1997) (which allows the quantification of the phenomenon thanks to the measurement of the extent of the deficit in the  $O_2$  emission Lavaud *et al.* 2002c). These two features are of importance to reduce the probability of ROS generation and of PS II damage (see before). The PS II CET thus constitutes an effective protective mechanism against photoinhibitory damage (Allakhverdiev *et al.* 1997). In diatoms, the amplitude of the PS II CET can be higher than in the green algae and cyanobacteria (Lavaud *et al.* 2002c), even though it is depending on the species so far examined (Lavaud *et al.* 2007). The dynamics of the PS II CET is also peculiar. Though qE is believed to be the most important rapid photoprotective process in diatoms, the PS II CET has been shown to be the first line of defence against an excess light exposure, developing faster (switched on within a second; Onno Feikema *et al.* 2006) and for lower light intensities than qE (Lavaud *et al.* 2002c, 2007) (Fig. 7A). As a consequence and in contrast to higher plants, the high amplitude of the PS II CET allows the cells to maintain the maximal capacity for photosynthesis while keeping qE low, up to nearly half-reduction of PS II which gives the photosynthetic apparatus a rather fast and flexible ability to react to rapid changes in irradiance (Behrenfeld *et al.* 1998; Ruban *et al.* 2004; Lavaud *et al.* 2007). In that framework, it has been shown that the diatoms are able of a much higher conversion efficiency of photosynthetic energy into biomass in a fluctuating light climate because of the different extent of alternative electron cycling, including the PS II CET (Wagner *et al.* 2006). Additionally, in diatom species isolated from an ecosystem which underwater light climate is very changing (estuary), the PS II CET is higher and faster than

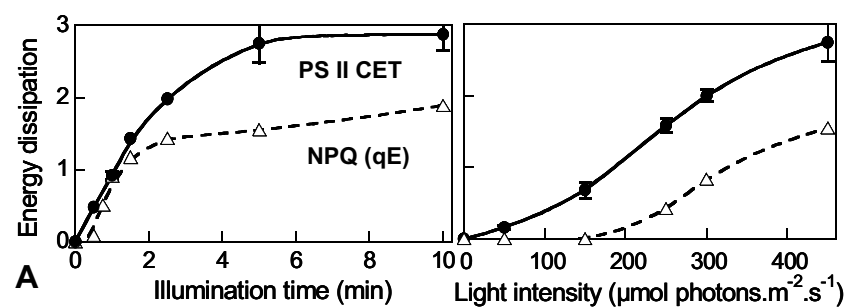

**Fig. 7 The PS II electron cycle (PS II CET) in diatoms.** (A) Kinetics of PS II CET and NPQ (qE) development in cells of the diatom *P. tricornutum* as a function of time exposure to an irradiance of  $450 \mu\text{mol photons}\cdot\text{m}^{-2}\cdot\text{s}^{-1}$  (left panel) and as a function of irradiance for a 5 min exposure (right panel) (adapted from Lavaud *et al.* 2002c). (B) The mechanistic model for the PS II CET in diatoms (adapted from an original scheme by W. O. Feikema). Chl, chlorophyll; Cyt, Cytochrome; LHC, light-harvesting complex; NPQ, non-photochemical fluorescence quenching; OEC, oxygen evolving complex; PQ, plastoquinone; PS II, photosystem II;  $P_{680}$ , Chl center; Q, quinones. The '?' refers to the fact that the pathways from Cytochrome b559 to  $P_{680}$  possibly via alternative donors of unknown identity are under discussion. See the text for a full description.

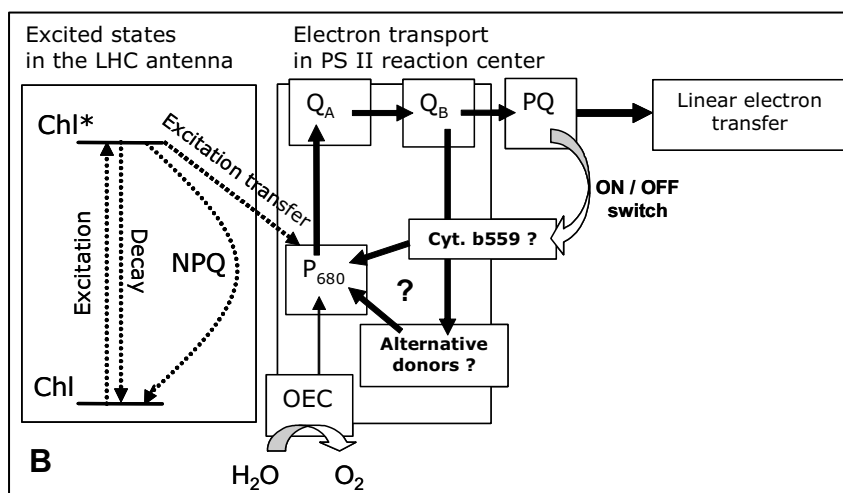

in species originating from an habitat where the light environment is much stable (open ocean, coast), providing the former with a higher flexibility in the regulation of photosynthesis through the fine partitioning of photochemistry versus photoprotection as a function of the irradiance (Lavaud *et al.* 2007).

Even if not fully described, it seems that the mechanism of the PS II CET in diatoms resembles the one in green microalgae (**Fig. 7B**). Three components play a major role. First, quinone  $Q_B$  from where the electrons are diverted from the linear pathway. This has been clearly demonstrated by the observation of reduced capacity for PS II CET in a *psbA* (D1) *P. tricornutum* mutant which shows a mutation within the  $Q_B$  pocket generating a disturbance in the spatial arrangement of the pocket as well as in the redox state of  $Q_B$  as a function of light (Materna, Ng Chin Yue, Kroth and Lavaud, unpublished). Second, the PQ pool which irradiance-dependent redox state is the key trigger to switch on and off the PS II CET (Onno Feikema *et al.* 2006) (T. Jakob and J. Lavaud, unpublished). Indeed, in *psbA* *P. tricornutum* mutants, where the redox state of the PQ pool is shifted to lower light intensities due to mutations in the neighbouring of the  $Q_B$  pocket, the extent of the PS II CET is nearly twice compared to the wild-type cells (Materna, Ng Chin Yue, Kroth and Lavaud, unpublished). Third, the cytochrome b559 which has been described and hypothesised to be the on/off switch in green algae (Prasil *et al.* 1996) and diatoms (Onno Feikema *et al.* 2006). A recent paper confirmed that the cytochrome b559 is well suited to play this role (Kaminskaya *et al.* 2007). Additionally, it is believed that there could be one or several alternative electron donor(s) between the cytochrome b559 and the P680. Even if it was first postulated that it could be the tyrosine  $Y_D$  (Lavaud *et al.* 2002c), it has been further ruled out from the PS II CET pathway (Onno Feikema *et al.* 2006).

### An evolutionary point of view of the fast photosynthetic regulatory mechanisms

In the brown algae, which are close relative of the diatoms and have a similar organization of the LHC antenna, qE can show similar high extent (Harker *et al.* 1999; Colombo-Pallotta *et al.* 2006) with a somehow similar regulation and importance of the xanthophylls (Rodrigues *et al.* 2002; Gévaert *et al.* 2003; Garcia-Mendoza and Colombo-Pallotta 2007) even though the XC involves the same pigments as in higher plants (**Table 2**). Furthermore, among the other groups of phytoplankton organisms a certain degree of variety concerning the amplitude and kinetics of the XC and qE exists (see Casper-Lindley and Bjorkman 1998; Juneau and Harrison 2005). Also, both the red algae and cyanobacteria which have extrinsic LHC systems (i.e. phycobilisomes, PBS) show a qE process even though the amplitude developed is weak (**Fig. 6B**, **Table 2**). The same remark holds true for the Prochlorophytes and their intrinsic Pcb antenna system (Bailey *et al.* 2005) (**Fig. 6B**). qE in these organisms does not depend on a XC (except few red algae species, see before). Still, in the red algae, qE is regulated by the transthylakoid  $\Delta pH$  as well as in higher plants and diatoms (Ritz

*et al.* 1999) and qE appears to be controlled by the xanthophylls ZX-AX or lutein depending on the species (Schubert *et al.* 2006) (**Table 2**). A lutein cycle has also been proven to be involved in qE in higher plants (Garcia-Plazaola *et al.* 2007). In the cyanobacteria, the process is totally different. It is believed to be a thermo-optic mechanism driven by blue light and taking place in the PBS where it involves a special carotenoid-binding protein (OCP) and the pigments ZX and/or the myxoxanthophyll (Cadoret *et al.* 2004; Scott *et al.* 2006; Wilson *et al.* 2007; Rakhimberdieva *et al.* 2007a). This thermo-optic effect depends on the light intensity and temperature but not on the photosynthetic electron transfer and coupled build-up of the transthylakoid  $\Delta pH$  (Cadoret *et al.* 2004; Wilson *et al.* 2006). Additionally, qE in the cyanobacteria and Prochlorophytes has been observed in conditions of iron depletion (Cadoret *et al.* 2004; Bailey *et al.* 2005; Wilson *et al.* 2007) during which a newly synthesized LHC chlorophyll-binding protein CP43' (*isaA* gene product) binds to the PBS/Pcbs and triggers energy dissipation (Ihalainen *et al.* 2005; Joshua *et al.* 2005). Still, the respective roles of CP43' and OCP in photoprotective energy dissipation are a source of debate (see Kirilovsky 2007), even if CP43' more and more appears to have a minor role in qE at least for the cyanobacteria (Rakhimberdieva *et al.* 2007b). Additionally, a possible involvement of special proteins, the 'High Light Induced Proteins' (HLIPs), which are believed to be involved in high light photoacclimation in both higher plants and cyanobacteria, has also been suggested (Havaux *et al.* 2003). It has been argued that qE in the cyanobacteria would serve to adjust the energy transfer within the PBS of an already acclimated system to environmental stress(es) (high light, iron deficiency), but would not serve to cope with rapid fluctuations in irradiances as in higher plants and diatoms; the state-transitions phenomenon playing this role. Hence, the qE process in cyanobacteria could very well be the ancestor of the more sophisticated mechanisms involving the XC encountered in higher plants and diatoms, and functioning as a feed-back process to the linear electron transport via the amplitude of the building of the transthylakoid  $\Delta pH$ . The red algae would then show an intermediary situation, the transthylakoid  $\Delta pH$  being mandatory for qE as well as the presence of de-epoxidised forms of xanthophylls but without XC. Also it seems that a special organisation of the LHC antenna is necessary with two features (**Table 2**): (1) the presence of a 'special' protein like PsbS in higher plants, Cbr and LI818 in the green microalgae, OCP in the cyanobacteria, (2) a high oligomeric organisation of the LHC polypeptides as it has been demonstrated both in the higher plants and the green microalgae (Swiatek *et al.* 2001; Elrad *et al.* 2002). In that framework, the hot actual question regarding the diatom qE is to identify the possible 'special' polypeptide(s) and to better understand how the polypeptide and pigment composition and the organisation of the antenna create a better match to reach a higher qE extent. A great step has been recently made in our understanding of the qE mechanism in diatoms (Beer *et al.* 2006; Lepetit *et al.* 2007; Gundermann and Büchel in press). Especially, some FCPs (FCP 6/7) related to the LI818 polypeptides of the green microalgae have been

**Table 2** Characteristics of the NPQ process in the main photosynthetic lineages.

LHC II antenna	Phylum	Chl and/or X binding protein	X	XC	$\Delta pH$	NPQ (qE)
PCB	Prochlorophytes	PCB, CP43'	ZX (?)	No	No	$\cong 0.5$
PBS	Cyanobacteria	OCP, CP43', HLIPs (?)	ZX, myxoX (?)	No	No	$\cong 1$
	Red algae	(?)	ZX, LT-epoxide	No	Yes	$\cong 2$
CABs or FCPs	Green algae	Cbr, CAB, PsbZ, LI818	AX-ZX	Yes	Yes	$\cong 2$
	Brown algae	(?)	AX-ZX	Yes	Yes	$\cong 3$ Up to 10
	Diatoms	FCP 6-7 (?)	DT	Yes	Yes	$\cong 3$ Up to 12
	Higher plants	PsbS, CAB, PsbZ	AX-ZX, LT-epoxide	Yes	Yes	$\cong 2$ Up to 8

AX, antheraxanthin; CAB, Chl *a* binding protein; Cbr, carotenoid binding protein; Chl, chlorophyll; DD, diadinoxanthin; DT, diatoxanthin; FCP, fucoxanthin Chl binding protein; HLIP, high light induced protein; LHC II, light-harvesting complex of the photosystem II; LI818, Light-induced 818 LHC protein; LT, lutein; NPQ, non-photochemical fluorescence quenching; OCP, orange carotenoid protein; Pcb; prochlorophyte Chl binding protein; PBS, phycobilisomes; X, xanthophyll; XC, xanthophyll cycle; ZX, zeaxanthin;  $\Delta pH$ , transthylakoid proton gradient.

proposed to be involved in NPQ via the binding of DT (Beer *et al.* 2006; Gundermann and Büchel in press). Also other polypeptides could as well promote NPQ (Guglielmi *et al.* 2005; Lepetit *et al.* 2007), this track seems very attractive since the recent finding that LI818 polypeptides are essential for NPQ to develop in *Chlamydomonas* (G. Peers and K. Niyogi., pers. comm.). To a larger extent, it is a very exciting area of future research to understand how a mechanism fulfilling the same role has evolved so differently among the photosynthetic lineages; part of the answer probably lying in the differences in the LHC proteins and pigments (Table 2).

In most of the higher plants, qE has an important role in the fast regulation of photosynthesis. It is accompanied by a powerful and fine regulated XC while the state-transitions mechanism is more secondary. Also the PS II CET plays an important role (Whimmarsh and Pakrasi 1996). In contrast, in green algae, the amplitude of qE (Elrad *et al.* 2002) and of the PS II CET (Lavaud *et al.* 2002c) are rather low but the state-transitions are essential. The same observation holds true for the cyanobacteria in general. It can be questioned if in diatoms the ability for high amplitude and fast kinetics of the XC, qE and the PS II CET are an adaptation to the lack of the state-transition mechanism, absent probably because of their special LHC organization. As described above, in the close related brown macroalgae, the amplitude of qE can also be as high as in diatoms even if the pigments involved in the XC are different. Still, the organization and composition of the LHC system are very similar and there are no state-transitions as in diatoms (Fork *et al.* 1991). Unfortunately, no data are available on the capacity of brown macroalgae for the PS II CET. It would be of interest to screen for this process together with the XC, qE and the state-transitions in brown algae as well as diatom relatives (other members of the Heterokontophytes) to define if the observation made recently in diatoms (Lavaud *et al.* 2002c, 2007) is a general rule. This is also of importance to draw and understand a possible physiological as well as evolutionary relationship between these fast regulatory processes.

### A possible role for the fast photoprotective mechanisms in the ecophysiology of diatoms

In higher plants, qE has been recently shown to help to maintain the fitness in a fluctuating light environment (Külheim *et al.* 2002), and both qE and the XC are essential components of the ecophysiology of photosynthesis of plants in nature (Demmig-Adams and Adams 2006) in comparison to other fast photoprotective mechanisms like the state-transitions (Frenkel *et al.* 2007). In phytoplankton, and especially in diatoms, *in situ* measurements showed that the amount of xanthophylls, the amplitude of the XC and subsequent qE photoprotection are essential for the organisms to maintain an optimal photosynthetic activity in turbulent waters where the vertical mixing exposes the cells to large fluctuations in irradiance (Kashino *et al.* 2002; Brunet *et al.* 2003; Eisner *et al.* 2003; Fujiki *et al.* 2003).

A number of studies have investigated the amount of DD and DT in response to the light environment of the microalgae, and often of diatoms, in different ecosystems: coastal sites (Brunet *et al.* 1993; Moline 1998) (Brunet *et al.* 2003; Fujiki *et al.* 2003; Müller and Wasmund 2003), frontal systems (Claustre *et al.* 1994; Brunet and Lizon 2003) and offshore areas (Bidigare *et al.* 1987; Olaiola *et al.* 1992; Kashino *et al.* 2002; Brunet *et al.* 2006). Interestingly, many of these works have used the kinetics of the XC to estimate mixing velocities of the water column, further illustrating how the XC kinetics fits quite well with the environmental constraints of the aquatic ecosystems the microalgae are submitted to like water turbulence and irradiance fluctuations (MacIntyre *et al.* 2000). In this context it is noteworthy that the first-order reaction time constant of the XC in diatoms is faster than the time needed for the irradiance to double in the coastal/estuarine turbulent waters (MacIntyre *et al.* 2000). On a yearly scale, photoprotection ability

in terms of DD amount and DD de-epoxidation extent appears to be directly correlated with the day length and the seasonal increase in irradiance (Brunet *et al.* 1993; Moline 1998; Fujiki *et al.* 2003). On a daily scale, the amount of DT fits well with the course of the sun, showing a sinusoidal pattern significantly related to the light intensity with a peak around noon especially in the upper layer of the water column (Brunet *et al.* 1993). The same time course holds true for qE, also along a depth profile, qE being high in the first meters of the water column and then disappearing (Falkowski and Raven 1997). Additionally, it has been observed in surface growing natural phytoplankton populations and in the diatom *Thalassiosira weissflogii* that the maximal photosynthetic rate was not decreased up to the photoinhibitory damaging of half of the number of active PS II (Behrenfeld *et al.* 1998). It has been shown that this was due to an increased ability in electron turnover through the remaining functional PS II. It could as well being also explained by the operation of the CET in the same PS II reaction centers (Lavaud *et al.* 2002c; Ruban *et al.* 2004; Lavaud *et al.* 2007).

A higher DD/Chl *a* ratio confers an adaptive advantage in allowing a fast photoacclimation along sharp gradients of light like the ones experienced by benthic diatoms resuspended in the water column in estuaries (Claustre *et al.* 1994; Brunet and Lizon 2003). Indeed, it appears that in controlled conditions as well as in nature, diatoms seem to be able to regulate the harvesting of light by a fine-tuning of their xanthophyll content. By doing so, diatoms maximise their photoprotection capacities without significantly affecting their ability for light collection under light-limiting conditions, another highly appreciable feature for living in a fluctuating light environment (Eisner *et al.* 2003; Fujiki *et al.* 2003; Lavaud *et al.* 2003; van de Poll *et al.* 2006). This ability was recently suggested to be endogenously regulated (Ragni and D'Alcala 2007). Other environmental cues, like the availability in nutrients, influence the size of the DD pool. Several studies have reported an increase in DD/Chl *a* in diatoms and other DD-containing organisms exposed to stressful conditions other than high irradiance, like nutrient shortage (Geider *et al.* 1993; Staehr *et al.* 2002; van de Poll *et al.* 2006), oxidative stress due to aldehyde exposure (Cassotti *et al.* 2005) or virus infection (Llewellyn *et al.* 2007), and more generally because of a slow down in the growth rate (Arsalane *et al.* 1994; Lavaud *et al.* 2002a; Pinto *et al.* 2003) and resting spore formation (Oku and Kamatani 1999). Still, as described before, the light intensity remains one of the main factor influencing the DD pool size and subsequent ability to produce DT.

The amplitude of the XC has been suggested to define the ecological success of a species or a group of phytoplankton regarding a given underwater light climate, and to define species succession (Meyer *et al.* 2000). For example, Fujiki *et al.* (2003) showed a species succession between diatoms and dinoflagellates in a bay with 7 successive diatom blooms in end of spring/beginning of summer: for all blooms three species dominated (*Nitzschia* sp., *Thalassiosira* sp. and *Chaetoceros* sp.) and cell proliferations were accompanied by an increase in DD-DT. Additionally, the XC and qE were shown to be involved in seasonal succession of benthic diatoms in estuaries (Serodio *et al.* 2005). Recent works on marine diatoms have also proved that both the XC and qE, as well as the PS II CET, are involved in the spatial distribution of diatom species (Lavaud *et al.* 2004; Strzepek and Harrison 2004; Dimier *et al.* 2007; Lavaud *et al.* 2007) confirming earlier observations of a differential photoadaptive response of diatom species/ecotypes isolated from aquatic habitat characterized by a different underwater light climate (Gallagher *et al.* 1984; Sakshaug *et al.* 1987). The authors concluded that the intra-genus/species variability observed would explain the amazing capacity of the diatoms to exploit the differences in underwater light climate and to occupy a wide range of ecological niches. This concept has been recently confirmed: the distribution of the photosynthetic *versus* photoprotective energy alloca-

tion as a function of light is drastically different in species originating from different habitats (Lavaud *et al.* 2007). Indeed, strains originating from estuaries which underwater light climate is characterized by light fluctuations with high amplitude and frequency show a higher (2.5 to 5 times) and faster switch on/off of qE and PS II CET. This ability provides the estuarine species with a higher flexibility in the regulation of photosynthesis and a more efficient photoprotection than the strains originating from the open ocean ecosystems where the water body and the light environment are more stable (MacIntyre *et al.* 2000; Lavaud *et al.* 2004, 2007). The difference in the amplitude and kinetics of qE between diatom strains from different habitats is due to a lower efficiency of DT to induce qE (Lavaud *et al.* 2004) likely to be due to a different LHC system organisation (J. Lavaud, unpublished). A similar observation involving qE and the XC has been made with coastal and offshore species (Dimier *et al.* 2007). The difference of photoprotection ability between open ocean and coastal species was suggested to be due to an adaptation to the low/high iron concentrations, respectively (Strzepek and Harrison 2004): by adapting their photosynthetic architecture to low iron concentrations, the oceanic species (*Thalassiosira oceanica*) have virtually lost the ability for qE making them unable to colonize the coastal/estuarine habitats where they would be out-competed by the better adapted indigene species (*T. weissflogii*). Ultimately this adaptation of photosynthesis regulation to estuarine-coastal/oceanic habitat is reflected in growth rate under fluctuating light conditions (Brand and Guillard 1981; Lavaud *et al.* 2007). Such an adaptation to ecosystems/niches through the amplitude and kinetics of the XC and qE process has also been reported in brown macroalgae (Rodrigues *et al.* 2002): the shallow water adapted *Laminaria digitata* shows high xanthophyll content and a high XC and qE in comparison to the deep water adapted *L. abyssalis* providing it with an effective high light resistance. The same holds true when comparing the higher and lower mediolittoral belt brown algae *Pelvetia canaliculata* and *L. saccharina*, respectively (Harker *et al.* 1999), as well as the surface and 18 m blades of the same organism: the giant brown kelp *Macrocystis pyrifera* (Colombo-Pallotta *et al.* 2006). Finally, qE has also been shown to drive the ecological niche occupancy of *Prochlorococcus* ecotypes, the surface growing ecotype (so-called 'high light' strain) showing a nearly six times higher qE than the deep water (50–150 m) growing 'low light' ecotype (Bailey *et al.* 2005).

Hence, it appears that the ability of phytoplankton, including the diatoms, to occupy a wide range of aquatic ecological niches depends critically on their capacity to exploit the differences in underwater light climate. The short photoprotective mechanisms are likely to be part of this capacity. It has been claimed that the general photoprotection capacities of diatoms could play an important role in their successful ecological adaptation to turbulent aquatic freshwater and marine habitats (Fogg 1991; MacIntyre *et al.* 2000; Lichtman and Klausmeier 2001; Falkowski *et al.* 2004). Especially, the ability of some diatom species to develop a high and fast qE and PS II CET would be responsible for their well known ability to out-compete the other phytoplankton groups in aquatic habitats where the light environment is stressful (light fluctuations periodically punctuated with excess irradiances) like the pelagic and benthic estuarine ecosystem (Blanchard *et al.* 2004; Koh *et al.* 2006) and the lakes at spring (Mitrovic *et al.* 2003; Huisman *et al.* 2004). All these observations support the hypothesis that fast photoprotective mechanisms might be part of a physiological network ensuring an unusual photosynthetic flexibility and defining the ecological success of some diatom species in a turbulent aquatic environment by allowing them to maintain an optimal photosynthetic production in deeply mixed waters (Lavaud *et al.* 2007). Also, it has been recently debated how modifications in the upper ocean turbulence, through its effect on the supply of nutrients and light, have shaped the functional and evolutionary ecology of diatoms and currently influence their geographical distri-

bution (Falkowski *et al.* 2004; Strzepek and Harrison 2004; Tozzi *et al.* 2004; Lavaud *et al.* 2007).

## CONCLUSION AND PROSPECTS

The present review is an attempt to describe the actual state of the art regarding the fast regulation of photosynthesis in diatoms in the context of the water column vertical mixing and their exposure to a fluctuating underwater light field. It is only recently that the fast processes of photoacclimation, like the NPQ (qE), have received large interest in diatoms in comparison to the green algae and higher plants. This is somewhat surprising regarding the central involvement of diatom photosynthesis in the marine primary productivity and aquatic biogeochemical cycles. Also recently, it was shown that these fast regulatory photoprotective processes provide the diatoms with an unusual photosynthetic flexibility. Both NPQ, including the XC controlling, and the PS II CET were shown to possibly influence the spatial distribution of diatoms as a function of the turbulence of the water column and the resulting change in light climate. Ultimately, these processes might explain, at least in part, the success of the diatoms in occupying a wide range of ecological niches by exploiting the differences in the light environment of both pelagic and benthic systems.

In a recent paper on the photoacclimation of phytoplankton in nature, Moore *et al.* (2006) concluded that 'Understanding photoacclimation and adaptation strategies in mixed layers is likely to require knowledge of the time scales and mechanisms for the different components of NPQ induction and relaxation [...]. Mechanistic understanding of interactions between NPQ, photoinhibition, and photoacclimation will also be required. These remain formidable research objectives'. Such remarks are especially true for diatoms due to the recent entering of the eco-/physiology studies in the post-genomic era (Montsant *et al.* 2004; Grossman 2005) and the simultaneous increasing development of tools for genetics in diatoms (for a recent example see Poulsen *et al.* 2006). Consequently, functional genomics is now already possible for understanding the mechanism of NPQ and the XC (the PS II CET has not yet reached this level of investigation). Additionally, the exponential improvement of biochemical approaches, especially for purifying and isolating FCPs, will soon allow investigating the mechanisms and their regulation at the molecular level (Gundermann and Büchel in press). Simultaneously, the coupling between fine functional genomics approaches and field work will push toward the elucidation of the exact role of these fast photoprotective processes and their potential importance in the ecology of the diatoms. A parallel challenge will be to understand the impact of these mechanisms on the Chl *a* fluorescence in order to improve the techniques/methods used for *in situ* photobiology measurements for the evaluation of the phytoplankton biomass, species composition and photosynthetic productivity (Wilhelm *et al.* 2003; Parésys *et al.* 2005; Perkins *et al.* 2006). In this framework, two tracks, for future investigations, with opposite scale of interest, can be defined: on one hand going deeper at the scale of the photosynthetic apparatus toward the gene level, and on the other hand going larger at the scale of the ecosystem toward the diatom community. To illustrate this approach, two questions are of central interest: 1) how the organisation and regulation of the photosynthetic apparatus creates a better match for a faster switch between photoprotection vs photochemistry energy allocation in diatoms, 2) what is the exact relationship between the capacity for fast photoprotection, niche occupancy, light availability and water turbulence? Answering these questions will help to better understand how the diatoms adapted to the challenge of maintaining optimal photosynthetic productivity in turbulent waters.

## ACKNOWLEDGEMENTS

The author thanks the University of Konstanz and the DFG (project LA 2368/2-1) for their financial support, Ansgar Gruber and Christiane Lichtlé for performing the pictures of Fig. 1A and 1B, respectively, Drs. G. Gulgielmi, K.K. Niyogi and W. Onno Feikema for providing the material which inspired the figures 4B, 6A and 7B, respectively, Prof. B.R. Green and Drs G. Peers and K.K. Niyogi for sharing some unpublished data, and Dr. J.-L. Mouget for critical reading and improvement of the manuscript. This review is dedicated to Dr. Anne-Lise Etienne, who initiated this work, for her 65<sup>th</sup> anniversary.

## REFERENCES

- Adamska I (2001) The Elip family of stress proteins in the thylakoid membranes of Pro- and Eukaryota. In: Aro EM, Andersson B (Eds) *Regulation of Photosynthesis*, Kluwer Academic Publishers, Dordrecht, The Netherlands, pp 487-505
- Allakhverdiev SI, Klimov VV, Carpentier R (1997) Evidence for the involvement of cyclic electron transport in the protection of photosystem II against photoinhibition: Influence of a new phenolic compound. *Biochemistry* **36**, 4149-4154
- Allen AE, Vardi A, Bowler C (2006) An ecological and evolutionary context for integrated nitrogen metabolism and related signalling pathways in marine diatoms. *Current Opinion in Plant Biology* **9**, 264-273
- Andersson B, Aro EM (2001) Photodamage and D1 protein turnover in Photosystem II. In: Aro EM, Andersson B (Eds) *Regulation of Photosynthesis*, Kluwer Academic Publishers, Dordrecht, The Netherlands, pp 377-393
- Anning T, MacIntyre HL, Pratt SM, Sammes PJ, Gibb S, Geider RJ (2000) Photoacclimation in the marine diatom *Skeletonema costatum*. *Limnology and Oceanography* **45**, 1807-1817
- Apt KE, Bhaya D, Grossman AR (1994) Characterization of genes encoding the light-harvesting proteins in diatoms: biogenesis of the fucoxanthin chlorophyll *a/c* protein complex. *Journal of Applied Phycology* **6**, 225-230
- Apt KE, Clendennen SK, Powers DA, Grossman AR (1995) The gene family encoding the fucoxanthin chlorophyll proteins from the brown alga *Macrocystis pyrifera*. *Molecular Genetics and Genomics* **246**, 445-464
- Armbrust EV, Berges JA, Bowler C, Green BR, Martinez D, Putnam, NH, Zhou S, Allen AE, Apt KE, Bechner M, Brzezinski MA, Chaal BK, Chiovitti A, Davis AK, Demaree MS, Detter JC, Glavina T, Goodstein D, Hadi MZ, Hellsten U, Hildebrand M, Jenkins BD, Jurka J, Kapitonov VV, Kröger N, Lau WWY, Lane TW, Larimer FW, Lippmeier JC, Lucas S, Medina M, Montsant A, Obornik M, Parker MS, Palenik B, Pazour GJ, Richardson PM, Rynearson TA, Saito MA, Schwartz DC, Thamatrakoln K, Valentin K, Vardi A, Wilkerson FP, Rokhsar DS (2004) The genome of the diatom *Thalassiosira pseudonana*: Ecology, evolution and metabolism. *Science* **306**, 79-86
- Arsalane W, Rousseau B, Duval J-C (1994) Influence of the pool size of the xanthophyll cycle on the effects of light stress in a diatom: Competition between photoprotection and photoinhibition. *Photochemistry and Photobiology* **60**, 237-243
- Bailey S, Mann NH, Robinson C, Scanlan D (2005) The occurrence of rapidly reversible non-photochemical quenching of chlorophyll *a* fluorescence in cyanobacteria. *FEBS Letters* **579**, 275-280
- Barber J, de las Rivas J (1993) A functional model for the role of cytochrome *b559* in the protection against donor and acceptor side photoinhibition. *Proceedings of the National Academy of Sciences USA* **90**, 10942-10946
- Barranguet C, Kromkamp J, Peene J (1998) Factors controlling primary production and photosynthetic characteristics of intertidal microphytobenthos. *Marine Ecology Progress Series* **173**, 117-126
- Bassi R, Caffarri S (2000) Lhc proteins and the regulation of photosynthetic light harvesting function by xanthophylls. *Photosynthesis Research* **64**, 243-256
- Bathke L, Rhiel E, Krumbein WE, Marquardt J (1999) Biochemical and immunochemical investigations on the light-harvesting system of the cryptophyte *Rhodomonas* sp.: Evidence for a Photosystem I specific antenna. *Plant Biology* **1**, 516-523
- Beer A, Gundermann K, Beckmann J, Büchel C (2006) Subunit composition and pigmentation of fucoxanthin-chlorophyll proteins in diatoms: Evidence for a subunit involved in diadinoxanthin and diatoxanthin binding. *Biochemistry* **45**, 13046-13053
- Behrenfeld MJ, Prasil O, Kolber ZS, Babin M, Falkowski PG (1998) Compensatory changes in Photosystem II electron turnover rates protect photosynthesis from photoinhibition. *Photosynthesis Research* **58**, 259-268
- Berkaloff C, Duval J-C, Hauswirth N, Rousseau B (1983) Freeze fracture study of thylakoids of *Fucus serratus*. *Journal of Phycology* **19**, 96-100
- Berkaloff C, Caron L, Rousseau B (1990) Subunit organization of PSI particles from brown algae and diatoms: polypeptide and pigments analysis. *Photosynthesis Research* **23**, 181-193
- Bhaya D, Grossman AR (1993) Characterization of gene clusters encoding the fucoxanthin chlorophyll proteins of the diatom *Phaeodactylum tricorutum*. *Nucleic Acids Research* **21**, 4458-4466
- Bigare RR, Smith RC, Baker KS, Marra J (1987) Oceanic primary production estimates from measurements of spectral irradiance and pigment concentrations. *Global Biogeochemical Cycles* **1**, 171-186
- Blanchard G, Guarini J-M, Dang C, Richard P (2004) Characterizing and quantifying photoinhibition in intertidal microphytobenthos. *Journal of Phycology* **40**, 692-696
- Brakemann T, Schlörmann W, Marquardt J, Nolte M, Rhiel E (2006) Association of fucoxanthin chlorophyll *a/c*-binding polypeptides with photosystems and phosphorylation in the centric diatom *Cyclotella cryptica*. *Protist* **157**, 463-475
- Brand LE, Guillard RRL (1981) The effects of continuous light and light intensity on the reproduction rates of twenty-two species of marine phytoplankton. *Journal of Experimental Marine Biology and Ecology* **50**, 119-132
- Brown JS (1989) Photosynthetic pigment organization in diatoms (Bacillariophyceae). *Journal of Phycology* **24**, 96-102
- Brunet C, Brylinski J-M, Lemoine Y (1993) *In situ* variations of the xanthophylls diadinoxanthin and diatoxanthin: photoadaptation and relationships with an hydrodynamical system of the Eastern English Channel. *Marine Ecology Progress Series* **102**, 69-77
- Brunet C, Casotti R, Aronne B, Vantrepotte V (2003) Measured photophysiological parameters used as tools to estimate vertical water movements in the coastal Mediterranean. *Journal of Plankton Research* **25**, 1413-1425
- Brunet C, Lizon F (2003) Tidal and diel periodicities of size fractionated phytoplankton pigment signatures at an offshore station in South-Eastern English Channel. *Estuarine and Coastal Shelf Sciences* **56**, 835-845
- Brunet C, Casotti R, Vantrepotte V, Corato F, Conversano F (2006) Pico-phytoplankton diversity and photophysiology in the Strait of Sicily (Mediterranean Sea) in summer. I. Mesoscale variations. *Aquatic Microbial Ecology* **44**, 127-141
- Büchel C, Wilhelm C (1992) Evidence for a lateral heterogeneity by patchwork-like areas enriched with photosystem I complexes in the three thylakoid lamellae of *Pleurochloris meiringensis* (Xanthophyceae). *Journal of Cryptogam Botany* **2**, 375-386
- Büchel C, Wilhelm C (1993) Isolation and characterization of a Photosystem I-associated antenna (LHC1) and a Photosystem I-core complex from the chlorophyll *c*-containing alga *Pleurochloris meiringensis* (Xanthophyceae). *Journal of Photochemistry and Photobiology B* **20**, 87-93
- Büchel C (2003) Fucoxanthin-chlorophyll proteins in diatoms: 18 and 19 kDa subunits assemble into different oligomeric states. *Biochemistry* **42**, 13027-13034
- Buma AGJ, Zemmeling HJ, Sjollem K, Gieskes WWC (1996) UVB radiation modifies protein and photosynthetic pigment content, volume and ultrastructure of marine diatoms. *Marine Ecology Progress Series* **142**, 47-54
- Cadoret J-C, Démoulière R, Lavaud J, van Gorkom H, Houmard J, Etienne A-L (2004) Dissipation of excess energy triggered by blue light in cyanobacteria with CP43' (isiA). *Biochimica Biophysica Acta* **1659**, 100-104
- Cahoon AB, Timko MP (2003) Biochemistry and regulation of chlorophyll synthesis. In: Larkum WD, Douglas SE, Raven JA (Eds) *Photosynthesis in Algae*, Kluwer Academic Publishers, Dordrecht, The Netherlands, pp 95-131
- Caron L, Berkaloff C, Duval J-C, Jupin H (1987) Chlorophyll fluorescence transients from the diatom *Phaeodactylum tricorutum*: relative rates of cyclic phosphorylation and chlororespiration. *Photosynthesis Research* **11**, 131-139
- Caron L, Brown JS (1987) Chlorophyll-carotenoid protein complexes from the diatom *Phaeodactylum tricorutum*: spectrophotometric, pigment and polypeptide analyses. *Plant and Cell Physiology* **28**, 775-785
- Caron L, Remy R, Berkaloff C (1988) Polypeptide composition of light-harvesting complexes from some algae and diatoms. *FEBS Letters* **229**, 11-15
- Casper-Lindley C, Bjorkman O (1998) Fluorescence quenching in four unicellular algae with different light-harvesting and xanthophyll-cycle pigments. *Photosynthesis Research* **56**, 277-289
- Casotti R, Mazza S, Brunet C, Vantrepotte V, Ianora A, Miralto A (2005) Growth inhibition and toxicity of the diatom aldehyde 2-*trans*,4-*trans*-decadienal on *Thalassiosira weissflogii* (Bacillariophyceae). *Journal of Phycology* **41**, 7-20
- Claquin P, Kromkamp J, Martin-Jezequel V (2004) Relationship between photosynthetic metabolism and cell cycle in a synchronized culture of the marine alga *Cylindrocapsa fusiformis* (Bacillariophyceae). *European Journal of Phycology* **39**, 33-41
- Claustre H, Kerhervé P, Marty J-C, Prieur L (1994) Phytoplankton photoadaptation related to some frontal physical processes. *Journal of Marine Systems* **5**, 251-265
- Cogdell RJ (2006) The structural basis of non-photochemical quenching revealed? *Trends in Plant Sciences* **11**, 59-60
- Colombo-Pallotta MF, Garcia-Mendoza E, Ladah LB (2006) Photosynthetic performance, light absorption, and pigment composition of *Macrocystis pyrifera* (Laminariales, Phaeophyceae) blades from different depths. *Journal of Phycology* **42**, 1225-1234
- de Martino A, Douady D, Rousseau B, Duval J-C, Caron L (1997) Characterization of two light-harvesting subunits isolated from the brown alga *Pelvetia canaliculata*: Heterogeneity of xanthophyll distribution. *Photochemistry*



- and *Photobiology* **66**, 190-197
- de Martino A, Douady D, Quinet-Szely M, Rousseau B, Crépineau F, Apt KE, Caron L** (2000) The light-harvesting antenna of brown algae. Highly homologous proteins encoded by a multigene family. *European Journal of Biochemistry* **267**, 5540-5549
- Dekker JP, Boekema EJ** (2005) Supramolecular organization of thylakoid membrane proteins in green plants. *Biochimica Biophysica Acta* **1706**, 12-39
- Demers S, Roy S, Gagnon R, Vignault C** (1991) Rapid light-induced changes in cell fluorescence and in xanthophyll-cycle pigments of *Alexandrium excavatum* (Dinophyceae) and *Thalassiosira pseudonana* (Bacillariophyceae): a photo-protection mechanism. *Marine Ecology Progress Series* **76**, 185-193
- Demmig-Adams B, Adams WWI** (2006) Photoprotection in an ecological context: the remarkable complexity of thermal energy dissipation. *New Phytologist* **172**, 11-21
- Dimier C, Corato F, Saviello G, Brunet C** (2007) Photophysiological properties of the marine picoeukaryote *Picochlorum* RCC237 (Trebouxiophyceae, Chlorophyta). *Journal of Phycology* **43**, 275-283
- Dimier C, Corato F, Tramontano F, Brunet C** (2007) Photoprotective capacity as functional trait in planktonic algae: relationship between xanthophyll cycle and ecological characteristics in three diatoms. *Journal of Phycology* **43**, 937-947
- Döhler G, Hagmeier E** (1997) UV effects on pigments and assimilation of  $^{15}\text{N}$ -ammonium and  $^{15}\text{N}$ -nitrate by natural marine phytoplankton of the North Sea. *Botanica Acta* **110**, 481-488
- Eisner LB, Twardowski MS, Cowles TJ, Perry MJ** (2003) Resolving phytoplankton photoprotective: photosynthetic carotenoid ratios on fine scales using *in situ* absorption measurements. *Limnology and Oceanography* **48**, 632-646
- Elrad D, Niyogi KK, Grossman AR** (2002) A major light-harvesting polypeptide of photosystem II functions in thermal dissipation. *The Plant Cell* **14**, 1801-1816
- Eppard M, Rhiel E** (1998) The genes encoding light-harvesting subunits of *Cyclotella cryptica* (Bacillariophyceae) constitute a complex and heterogeneous family. *Molecular and General Genetics* **260**, 335-345
- Eppard M, Krumbein WE, von Haeselaer A, Rhiel E** (2000) Characterization of *fcp4* and *fcp12*, two additional genes encoding light harvesting proteins of *Cyclotella cryptica* (Bacillariophyceae) and phylogenetic analysis of this complex gene family. *Plant Biology* **2**, 283-289
- Eppard M, Rhiel E** (2000) Investigations on gene copy number, introns and chromosomal arrangement of genes encoding the fucoxanthin chlorophyll *a/c*-binding proteins of the centric diatom *Cyclotella cryptica*. *Protist* **151**, 27-39
- Eskling M, Emanuelson A, Akerlund HE** (2001) Enzymes and mechanisms for violaxanthin-zeaxanthin conversion. In: Aro EM, Andersson B (Eds) *Regulation of Photosynthesis*, Kluwer Academic Publishers, Dordrecht, The Netherlands, pp 433-452
- Estrada M, Berdalet E** (1997) Phytoplankton in a turbulent world. *Scientia Marina* **61** (Suppl. 1), 125-140
- Falkowski PG** (1994) The role of phytoplankton photosynthesis in global biogeochemical cycles. *Photosynthesis Research* **39**, 235-258
- Falkowski PG, Raven JA** (1997) *Aquatic Photosynthesis*, Blackwell Science Publishers, Malden, USA, 375 pp
- Falkowski PG, Barber RT, Smetacek VA** (1998) Biogeochemical controls and feedbacks on ocean primary production. *Science* **280**, 200-206
- Falkowski PG, Kolber Z** (1986) Evidence for cyclic electron flow around Photosystem II in *Chlorella pyrenoidosa*. *Plant Physiology* **81**, 310-312
- Falkowski PG, Katz ME, Knoll AH, Quigg A, Raven JA, Schofield O, Taylor FRJ** (2004) The evolution of modern phytoplankton. *Science* **305**, 354-360
- Field CB, Behrenfeld MJ, Randerson JT, Falkowski P** (1998) Primary production of the biosphere: integrating terrestrial and oceanic components. *Science* **281**, 237-240
- Fietz S, Nicklisch A** (2002) Acclimation of the diatom *Stephanodiscus neoastraea* and the cyanobacterium *Planktothrix agardhii* to simulated natural light fluctuations. *Photosynthesis Research* **72**, 95-106
- Flöder S, Urabe J, Kawabata Z-I** (2002) The influence of fluctuating light intensities on species composition and diversity of natural phytoplankton communities. *Oecologia* **133**, 395-401
- Fogg GE** (1991) The phytoplanktonic ways of life. *New Phytologist* **118**, 191-192
- Fork DC, Herbert SK, Malkin S** (1991) Light energy distribution in the brown alga *Macrocystis pyrifera* (giant kelp). *Plant Physiology* **95**, 731-739
- Frank HA, Cua A, Chynwat V, Young A, Gosztola D, Wasielewski MR** (1994) Photophysics of the carotenoids associated with the xanthophyll cycle in photosynthesis. *Photosynthesis Research* **41**, 389-395
- Frank HA, Cua A, Chynwat V, Young A, Gosztola D, Wasielewski MR** (1996) The lifetimes and energies of the first excited singlet states of diadinoxanthin and diatoxanthin: the role of these molecules in excess energy dissipation in algae. *Biochimica et Biophysica Acta* **1277**, 243-252
- Frank HA, Bautista JA, Josue JS, Young AJ** (2000) Mechanism of non-photochemical quenching in green plants: energies of the lowest excited singlet states of violaxanthin and zeaxanthin. *Biochemistry* **39**, 2831-2837
- Friedman AL, Alberte RS** (1984) A diatom light-harvesting pigment-protein complex. Purification and characterization. *Plant Physiology* **76**, 483-489
- Friedman AL, Alberte RS** (1987) Phylogenetic distribution of the major diatom light-harvesting pigment-protein determined by immunological methods. *Journal of Phycology* **23**, 427-433
- Frenkel M, Bellafiore S, Rochaix J-D, Jansson S** (2007) Hierarchy amongst photosynthetic acclimation responses for plant fitness. *Physiologia Plantarum* **129**, 455-459
- Fujiki T, Toda T, Kikuchi T, Taguchi S** (2003) Photoprotective response of xanthophyll pigments during phytoplankton blooms in Sagami Bay, Japan. *Journal of Plankton Research* **25**, 317-322
- Galitano MGI, Niedzwiedzki D, Deal C, Birge RR, Frank HA** (2007) Cation radicals of xanthophylls. *Photosynthesis Research* **94**, 67-78
- Gallagher JC, Wood AM, Alberte RS** (1984) Ecotypic differentiation in the marine diatom *Skeletonema costatum*: influence of the light intensity on the photosynthetic apparatus. *Marine Biology* **82**, 121-134
- Garcia-Mendoza E, Colombo-Pallotta MF** (2007) The giant kelp *Macrocystis pyrifera* presents a different nonphotochemical quenching control than in higher plants. *New Phytologist* **173**, 526-536
- Garcia-Plazaola JI, Matsubara S, Osmond CB** (2007) The lutein epoxide cycle in higher plants: its relationships to other xanthophyll cycles and possible functions. *Functional Plant Biology* **34**, 759-773
- Geel C, Versluis W, Snel JFH** (1997) Estimation of oxygen evolution by marine phytoplankton from measurement of the efficiency of Photosystem II electron flow. *Photosynthesis Research* **51**, 61-70
- Geider RJ, la Roche J, Greene RM, Olaizola M** (1993) Response of the photosynthetic apparatus of *Phaeodactylum tricorutum* (Bacillariophyceae) to nitrate, phosphate or iron starvation. *Journal of Phycology* **29**, 755-766
- Gévaert F, Créach A, Davoult D, Migné A, Levavasseur G, Arzel P, Holl A-C, Lemoine Y** (2003) *Laminaria saccharina* photosynthesis measured *in situ*: photoinhibition and xanthophyll cycle during a tidal cycle. *Marine Ecology Progress Series* **247**, 43-50
- Gilmore AM, Yamamoto HY** (1991) Zeaxanthin formation and energy-dependent fluorescence quenching in pea chloroplasts under artificially mediated linear and cyclic electron transport. *Plant Physiology* **96**, 635-643
- Goedheer JC** (1970) On the pigment system of brown algae. *Photosynthetica* **4**, 97-106
- Goerick R, Welschmeyer NA** (1992) Pigment turnover in the marine diatom *Thalassiosira weissflogii*. II. The  $^{14}\text{CO}_2$ -labeling kinetics of carotenoids. *Journal of Phycology* **25**, 507-517
- Goss R, Bohme K, Wilhelm C** (1998) The xanthophyll cycle of *Mantoniella squamata* converts violaxanthin into antheraxanthin but not to zeaxanthin. Consequences for the mechanism of enhanced non-photochemical energy dissipation. *Planta* **205**, 613-621
- Goss R, Hewes H, Wilhelm C** (1999) Stimulation of the diadinoxanthin cycle by UV-B radiation in the diatom *Phaeodactylum tricorutum*. *Photosynthesis Research* **59**, 73-80
- Goss R, Lohr M, Latowski D, Grzyb J, Vieler A, Wilhelm C, Strzalka K** (2005) Role of hexagonal structure-forming lipids in diadinoxanthin and violaxanthin solubilization and de-epoxidation. *Biochemistry* **44**, 4028-4036
- Goss R, Ann Pinto E, Wilhelm C, Richter M** (2006) The importance of a highly active and delta-pH-regulated diatoxanthin epoxidase for the regulation of the PS II antenna function in diadinoxanthin cycle containing algae. *Journal of Plant Physiology* **163**, 1008-1021
- Green BR, Kuhlbrandt W** (1995) Sequence conservation of light-harvesting and stress-response proteins in relation to the three-dimensional molecular structure of LHCII. *Photosynthesis Research* **44**, 139-148
- Green BR, Durnford DG** (1996) The chlorophyll-carotenoid proteins of oxygenic photosynthesis. *Annual Review of Plant Physiology and Plant Molecular Biology* **47**, 685-714
- Green BR** (2003) The evolution of light-harvesting antennas. In: Green BR, Parson WW (Eds) *Light-Harvesting Antennas in Photosynthesis*, Kluwer Academic Publishers, Dordrecht, The Netherlands, pp 129-168
- Grobelaar J** (2006) Photosynthetic response and acclimation of microalgae to light fluctuations. In: Subba Rao DV (Ed) *Algal Cultures Analogues of Blooms and Applications*, Science Publishers, Enfield, USA, pp 671-683
- Grossman AR, Manodori A, Snyder D** (1990) Light-harvesting proteins of diatoms: their relationship to the chlorophyll *a/b* binding proteins of the higher plants and their mode of transport into plastids. *Molecular and General Genetics* **224**, 91-100
- Grossman AR** (2005) Paths toward algal genomics. *Plant Physiology* **137**, 410-427
- Grouneva I, Jakob T, Wilhelm C, Goss R** (2006) Influence of ascorbate and pH on the activity of the xanthophyll cycle-enzyme diadinoxanthin de-epoxidase. *Physiologia Plantarum* **126**, 205-211
- Gruber A, Vugrinec S, Hempel F, Gould SB, Maier UG, Kroth PG** (2007) Protein targeting into complex diatom plastids: functional characterisation of a specific targeting motif. *Plant Molecular Biology* **64**, 519-530
- Guglielmi G, Lavaud J, Rousseau B, Etienne A-L, Houmard J, Ruban AV** (2005) The light-harvesting antenna of the diatom *Phaeodactylum tricorutum* - Evidence for a diadinoxanthin-binding subcomplex. *FEBS Journal* **272**, 4339-4348
- Gugliemelli LA** (1984) Isolation and characterization of pigment-protein particles from the light-harvesting complex of *Phaeodactylum tricorutum*. *Bio-*

- chimica et Biophysica Acta* **766**, 45-50
- Gundermann K, Büchel C** The fluorescence yield of the trimeric fucoxanthin-chlorophyll-protein FCPa in the diatom *Cyclotella meneghiniana* is dependent on the amount of bound diatoxanthin. *Photosynthesis Research* in press
- Harker M, Berkaloff C, Lemoine Y, Britton G, Young A, Duval J, Rmiki N, Rousseau B** (1999) Effects of high light and desiccation on the operation of the xanthophyll cycle in two marine brown algae. *European Journal of Phycology* **34**, 35-42
- Harrison KG** (2000) Role of increased marine silica input on paleo-pCO<sub>2</sub> levels. *Paleoceanography* **15**, 292-298
- Havaux M, Niyogi KK** (1999) The violaxanthin cycle protects plants from photooxidative damage by more than one mechanism. *Proceedings of the National Academy of Sciences USA* **96**, 8762-8767
- Havaux M, Guedeney G, He Q, Grossman AR** (2003) Elimination of high-light-inducible polypeptides related to eukaryotic chlorophyll *a/b*-binding proteins results in aberrant photoacclimation in *Synechocystis* PCC6803. *Biochimica et Biophysica Acta* **1557**, 21-33
- Hiller RG, Bardin A-M, Nabderyk E** (1987) The secondary structure content of pigment-protein complexes from the thylakoids of two Chromophyte algae. *Biochimica et Biophysica Acta* **894**, 365-369
- Holt NE, Zigmantas D, Valkunas L, Li XP, Niyogi KK, Fleming GR** (2005) Carotenoid cation formation and the regulation of photosynthetic light harvesting. *Science* **307**, 433-436
- Horton P, Wentworth M, Ruban A** (2005) Control of the light-harvesting function of chloroplast membranes: The LHCII-aggregation model for non-photochemical quenching. *FEBS Letters* **579**, 4201-4206
- Huisman J, Sharples J, Stroom JM, Visser PM, Kardinaal WEA, Verspagen JMH, Sommeijer B** (2004) Changes in turbulent mixing shift competition for light between phytoplankton species. *Ecology* **85**, 2960-2970
- Ihalainen JA, D'Haene S, Yeremenko N, van Roon H, Arteni AA, Boekema EJ, van Grondelle R, Matthijs HCP, Dekker JP** (2005) Aggregates of the chlorophyll-binding protein IsiA (CP43') dissipate energy in cyanobacteria. *Biochemistry* **44**, 10846-10853
- Jakob T, Goss R, Wilhelm C** (1999) Activation of diadinoxanthin de-epoxidase due to a chlororespiratory proton gradient in the dark in the diatom *Phaeodactylum tricornutum*. *Plant Biology* **1**, 76-82
- Jakob T, Wilhelm C** (2001) Unusual pH-dependence of diadinoxanthin de-epoxidase activation causes chlororespiratory induced accumulation of diatoxanthin in the diatom *Phaeodactylum tricornutum*. *Journal of Plant Physiology* **158**, 383-390
- Jakob T, Wagner H, Stehfest K, Wilhelm C** (2007) A complete energy balance from photons to new biomass reveals a light- and nutrient-dependent variability in the metabolic costs of carbon assimilation. *Journal of Experimental Botany* **58**, 2101-2112
- Janssen M, Bathke L, Marquardt J, Krumbein WE, Rhiel E** (2001) Changes in the photosynthetic apparatus of diatoms in response to low and high light intensities. *International Microbiology* **4**, 27-33
- Johnson MP, Havaux M, Triantaphyllidès C, Ksas B, Pascal AA, Robert B, Davison PA, Ruban AV, Horton P** (2007) Elevated zeaxanthin bound to oligomeric LHCII enhances the resistance of Arabidopsis to photo-oxidative stress by a lipid-protective, anti-oxidant mechanism. *The Journal of Biological Chemistry* **282**, 22605-22618
- Joshua S, Bailey S, Mann NH, Mullineaux CW** (2005) Involvement of phycobilisome diffusion in energy quenching in cyanobacteria. *Plant Physiology* **138**, 1577-1585
- Juneau P, Harrison PJ** (2005) Comparison by PAM fluorometry of photosynthetic activity of nine marine phytoplankton grown under identical conditions. *Photochemistry and Photobiology* **81**, 649-653
- Jung H-S, Niyogi KK** (2006) Molecular analysis of photoprotection of photosynthesis. In: Demmig-Adams B, Adams WWI, Mattoo AK (Eds) *Photoprotection, Photoinhibition, Gene Regulation and Environment*, Kluwer Academic Publishers, Dordrecht, The Netherlands, pp 127-143
- Kaminskaya O, Shuvalov VA, Renger G** (2007) Two reaction pathways for transformation of high potential cytochrome b559 of PSII into the intermediate potential form. *Biochimica et Biophysica Acta* **1767**, 550-558
- Kashino Y, Kudoh S, Hayashi Y, Suzuki Y, Odate T, Hirawake T, Satoh K, Fukuchi M** (2002) Strategies of phytoplankton to perform effective photosynthesis in the North Water. *Deep-Sea Research Pt II* **49**, 5049-5061
- Kashino Y, Kudoh S** (2003) Concerted response of xanthophyll-cycle pigments in a marine diatom, *Chaetoceros gracilis*, to shifts in light condition. *Phycology Research* **51**, 168-172
- Katoh T, Ehara T** (1990) Supramolecular assembly of fucoxanthin-chlorophyll-protein complexes isolated from a brown alga, *Petanolia fasciata*. Electron microscopic studies. *Plant Cell Physiology* **31**, 439-447
- Keeling P** (2004) A brief history of plastids and their hosts. *Protist* **155**, 3-7
- Kirilovsky D** (2007) Photoprotection in cyanobacteria: the orange carotenoid protein (OCP)-related non-photochemical quenching mechanism. *Photosynthesis Research* **93**, 7-16
- Kirk JTO** (1977) Thermal dissociation of fucoxanthin protein binding in pigment complexes from chloroplasts of *Hormosira* (Phaeophyta). *Plant Science Letters* **9**, 373-380
- Koh C-H, Khim JS, Araki H, Yamanishi H, Mogi H, Koga K** (2006) Tidal resuspension of microphytobenthic chlorophyll *a* in a Nanaura mudflat, Saga, Ariake Sea, Japan: flood-ebb and spring-neap variations. *Marine Ecology Progress Series* **312**, 85-100
- Kowalik KV, Stobe B, Schaffran I, Kroth-Pancic P, Freier U** (1995) The chloroplast genome of a chlorophyll *a+c*-containing alga, *Odontella sinensis*. *Plant Molecular Biology Reports* **13**, 336-342
- Kramer DM, Sacksteder CA, Cruz JA** (1999) How acidic is the lumen? *Photosynthesis Research* **60**, 151-163
- Kramer DM, Avenson TJ, Edwards GE** (2004) Dynamic flexibility in the light reactions of photosynthesis governed by both electron and proton transfer reactions. *Trends in Plant Science* **9**, 349-357
- Kromkamp J, Limbeck M** (1993) Effect of short-term variation in irradiance on light harvesting and photosynthesis of the marine diatom *Skeletonema costatum*: a laboratory study simulating vertical mixing. *Journal of Genetic Microbiology* **139**, 2277-2284
- Kroth P, Strotmann H** (1999) Diatom plastids: secondary endocytobiosis, plastid genome and protein import. *Physiologia Plantarum* **107**, 136-141
- Kroth PG** (2002) Protein transport into secondary plastids and the evolution of primary and secondary plastids. *International Review of Cytobiology* **221**, 191-255
- Kroth-Pancic PG** (1995) Nucleotide sequence of two cDNAs encoding fucoxanthin chlorophyll *a/c* proteins in the diatom *Odontella sinensis*. *Plant Molecular Biology* **27**, 825-828
- Kuhlbrandt W, Wang DN, Fujiyoshi Y** (1994) Atomic model of plant light-harvesting complex by electron crystallography. *Nature* **367**, 614-621
- Külheim C, Agren J, Jansson S** (2002) Rapid regulation of light harvesting and plant fitness in the field. *Science* **297**, 91-93
- Lang M, Kroth PG** (1998) Diatom fucoxanthin chlorophyll *a/c*-binding protein (FCP) and land plant light-harvesting proteins use a similar pathway for thylakoid membrane insertion. *The Journal of Biological Chemistry* **276**, 7985-7991
- Larkum AWD** (2003) Light-harvesting systems in algae. In: Larkum WD, Douglas SE, Raven JA (Eds) *Photosynthesis in Algae*, Kluwer Academic Publishers, Dordrecht, The Netherlands, pp 277-304
- Latowski D, Grzyb J, Strzalka K** (2004) The xanthophyll cycle - molecular mechanism and physiological significance. *Acta Physiologia Plantarum* **26**, 197-212
- Lavaud J, Rousseau B, van Gorkom H, Etienne A-L** (2002a) Influence of the diadinoxanthin pool size on photoprotection in the marine planktonic diatom *Phaeodactylum tricornutum*. *Plant Physiology* **129**, 1398-1406
- Lavaud J, Rousseau B, Etienne A-L** (2002b) In diatoms, a transthylakoidal proton gradient alone is not sufficient for non-photochemical fluorescence quenching. *FEBS Letters* **523**, 163-166
- Lavaud J, van Gorkom H, Etienne A-L** (2002c) Photosystem II electron transfer cycle and chlororespiration in planktonic diatoms. *Photosynthesis Research* **74**, 49-57
- Lavaud J, Rousseau B, Etienne A-L** (2003) Enrichment of the light-harvesting complex in diadinoxanthin and implications for the nonphotochemical fluorescence quenching in diatoms. *Biochemistry* **42**, 5802-5808
- Lavaud J, Rousseau B, Etienne A-L** (2004) General features of photoprotection by energy dissipation in planktonic diatoms (Bacillariophyceae). *Journal of Phycology* **40**, 130-137
- Lavaud J, Kroth P** (2006) In diatoms, the transthylakoidal proton gradient regulates the photoprotective non-photochemical fluorescence quenching beyond its control on the xanthophyll cycle. *Plant Cell Physiology* **47**, 1010-1016
- Lavaud J, Strzepak RF, Kroth PG** (2007) Photoprotection capacity differs among diatoms: Possible consequences on the spatial distribution of diatoms related to fluctuations in the underwater light climate. *Limnology and Oceanography* **52**, 1188-1194
- Lepetit B, Volke D, Szabo M, Hoffmann R, Garab G, Wilhelm C, Goss R** (2007) Spectroscopic and molecular characterization of the oligomeric antenna of the diatom *Phaeodactylum tricornutum*. *Biochemistry* **46**, 9813-9822
- Lewis MR, Horne EPW, Cullen JJ, Oakey NS, Platt T** (1984) Turbulent motions may control phytoplankton photosynthesis in the upper ocean. *Nature* **311**, 49-50
- Lichtenthaler HK** (2007) Biosynthesis, accumulation and emission of carotenoids,  $\alpha$ -tocopherol, plastoquinone, and isoprene in leaves under high photosynthetic irradiance. *Photosynthesis Research* **92**, 163-179
- Lichtlé C, Spilar A, Duval J-C** (1992) Immunogold localization of light-harvesting and photosystem I complexes in the thylakoids of *Fucus serratus* (Phaeophyceae). *Protoplasma* **166**, 99-106
- Lichtlé C, Arsalane W, Duval JC, Passaquet C** (1995) Characterization of the light-harvesting complex of *Gyrodactylus stellifer* (Chrysophyceae) and effect of light stress. *Journal of Phycology* **31**, 380-387
- Lichtman E, Klausmeier CA** (2001) Competition of phytoplankton under fluctuating light. *American Naturalist* **157**, 170-187
- Litchman E** (2000) Growth rates of phytoplankton under fluctuating light. *Freshwater Biology* **44**, 223-235
- Llewellyn CA, Evans C, Ains RL, Cook I, Bale N, Wilson WH** (2007) The response of carotenoids and chlorophylls during virus infection of *Emiliana huxleyi* (Prymnesiopyceae). *Journal of Experimental Marine Biology and Ecology* **344**, 101-112
- Lohmann M, Döhler G, Huckenbeck N, Verdini S** (1998) Effects of UV radiation of different wavebands on pigmentation, <sup>15</sup>N-ammonium uptake, amino

- acid pools and adenylate contents of marine diatoms. *Marine Biology* **130**, 501-507
- Lohr M, Wilhelm C** (1999) Algae displaying the diadinoxanthin cycle also possess the violaxanthin cycle. *Proceedings of the National Academy of Sciences USA* **96**, 8784-8789
- Lohr M, Wilhelm C** (2001) Xanthophyll synthesis in diatoms: quantification of putative intermediates and comparison of pigment conversion kinetics with rate constants derived from a model. *Planta* **212**, 382-391
- Long SP, Humphries S, Falkowski PG** (1994) Photoinhibition of photosynthesis in nature. *Annual Review of Plant Physiology and Plant Molecular Biology* **45**, 633-662
- Luis P, Behnke K, Toepel J, Wilhelm C** (2006) Parallel analysis of transcripts levels and physiological key parameters allows the identification of stress phase gene markers in *Chlamydomonas reinhardtii* under copper stress. *Plant, Cell and Environment* **29**, 2043-2054
- MacIntyre HL, Kana TM, Geider RJ** (2000) The effect of water motion on short-term rates of photosynthesis by marine phytoplankton. *Trends in Plant Science* **5**, 12-17
- Macpherson AN, Hiller RG** (2003) Light-harvesting systems in chlorophyll *c*-containing algae. In: Green BR, Parson WW (Eds) *Light-Harvesting Antennas in Photosynthesis*, Kluwer Academic Publishers, Dordrecht, The Netherlands, pp 325-352
- Mann DG** (1999) The species concept in diatoms. *Phycologia* **38**, 437-495
- Marra J** (1978) Effect of short-term variations in light intensity on photosynthesis of a marine phytoplankton: a laboratory simulation study. *Marine Biology* **46**, 191-202
- Martinson TA, Ikeuchi M, Plumley FG** (1998) Oxygen-evolving diatom thylakoid membranes. *Biochimica et Biophysica Acta* **1409**, 72-86
- Mewes H, Richter M** (2002) Supplementary ultraviolet-B radiation induces a rapid reversal of the diadinoxanthin cycle in the strong light-exposed diatom *Phaeodactylum tricorutum*. *Plant Physiology* **130**, 1527-1535
- Meyer AA, Tackx M, Daro N** (2000) Xanthophyll cycling in *Phaeocystis globosa* and *Thalassiosira* sp.: a possible mechanism for species succession. *Journal of Sea Research* **43**, 373-384
- Mimuro M, Akimoto S** (2003) Carotenoids of light harvesting systems: Energy transfer processes from fucoxanthin and peridinin to chlorophyll. In: Larkum WD, Douglas SE, Raven JA (Eds) *Photosynthesis in Algae*, Kluwer Academic Publishers, Dordrecht, The Netherlands, pp 335-349
- Mitrovic SM, Howden CG, Bowling LC, Buckney RT** (2003) Unusual alometry between *in situ* growth of freshwater phytoplankton under static and fluctuating light environments: possible implications for dominance. *Journal of Plankton Research* **25**, 517-526
- Miyake C, Osada K** (2003) The water-water cycle in algae. In: Larkum WD, Douglas SE, Raven JA (Eds) *Photosynthesis in Algae*, Kluwer Academic Publishers, Dordrecht, The Netherlands, pp 183-204
- Moline MA** (1998) Photoadaptive response during the development of a coastal Antarctic diatom bloom and relationship to water column stability. *Limnology and Oceanography* **43**, 146-153
- Montsant A, Maheswari U, Bowler C, Lopez PJ** (2004) Diatomics: Toward diatom functional genomics. *Journal of Nanoscience and Nanotechnology* **5**, 1-11
- Montsant A, Allen AE, Coesel S, de Martino A, Falciatore A, Mangogna M, Siaut M, Heijde M, Jabbari K, Maheswari U, Rayko E, Vardi A, Apt KE, Berges JA, Chiovitti A, Davis AK, Thamtrakoln K, Hadi MZ, Lane TW, Lippmeier JC, Martinez D, Parker MS, Pazour GJ, Saito MA, Rokhsar DS, Armbrust EV, Bowler C** (2007) Identification and comparative genomic analysis of signalling and regulatory components in the diatom *Thalassiosira pseudonana*. *Journal of Phycology* **43**, 585-604
- Moore CM, Suggett D, Hickman AE, Kim Y-N, Tweddle JF, Sharples J, Geider RJ, Holligan PM** (2006) Phytoplankton photoacclimation and photoadaptation in response to environmental gradients in a shelf sea. *Limnology and Oceanography* **5**, 936-949
- Mortain-Bertrand A, Falkowski PG** (1989) Evidence for a relation between fluorescence and carotenoids: a way to improve models of primary productivity. *Compte Rendus de l'Académie des Sciences Paris* **309**, 13-18
- Mouget J-L, Tremblin G, Morant-Manceau A, Morancés M, Robert J-M** (1999) Long-term photoacclimation of *Haslea ostrearia* (Bacillariophyta): effect of irradiance on growth rates, pigment content and photosynthesis. *European Journal of Phycology* **34**, 109-115
- Müller AM, Wasmund N** (2003) Photophysiology of surface phytoplankton communities in a transect from the mouth of Peene-strom to the Arkona Sea (Baltic). *International Review of Hydrobiology* **88**, 482-497
- Müller P, Li X-P, Niyogi KK** (2001) Non-photochemical quenching. A response to excess light energy. *Plant Physiology* **125**, 1558-1566
- Nagao R, Ishii A, Tada O, Suzuki T, Dohmae N, Okumura A, Iwai M, Takahashi T, Kashino Y, Enami I**. Isolation and characterization of oxygen-evolving thylakoid membranes and Photosystem II particles from a marine diatom *Chaetoceros gracilis*. *Biochimica et Biophysica Acta* in press
- Neale PJ** (1987) Algal photoinhibition and photosynthesis in the aquatic environment. In: Kyle DJ, Osmond CB, Arntzen CJ (Eds) *Photoinhibition*, Elsevier Science Publishers B.V., Amsterdam, The Netherlands, pp 39-62
- Nebdal L, Samson G, Whitmarsh J** (1992) Redox state of a one electron component controls the rate of photoinhibition of Photosystem II. *Proceedings of the National Academy of Sciences USA* **89**, 7929-7933
- Nicklisch A** (1998) Growth and light absorption of some planktonic cyanobacteria, diatoms and Chlorophyceae under simulated natural light fluctuations. *Journal of Plankton Research* **20**, 105-119
- Niyogi KK, Grossman AR, Björkman O** (1998) *Arabidopsis* mutants define a central role for the xanthophyll cycle in the regulation of photosynthetic energy conversion. *The Plant Cell* **10**, 1121-1134
- Niyogi KK** (2000) Safety valves for photosynthesis. *Current Opinion in Plant Biology* **3**, 455-460
- Niyogi KK, Li X-P, Rosenberg V, Jung H-S** (2005) Is PsbS the site of non-photochemical quenching in photosynthesis? *Journal of Experimental Botany* **56**, 375-382
- Nugent JHA, Purton S, Evans MCW** (2003) Oxygenic photosynthesis in algae and cyanobacteria: Electron transfer in photosystems I and II. In: Larkum WD, Douglas SE, Raven JA (Eds) *Photosynthesis in Algae*, Kluwer Academic Publishers, Dordrecht, The Netherlands, pp 133-156
- Oeltjen A, Krumbein WE, Rhiel E** (2002) Investigations on transcript sizes, steady state mRNA concentrations and diurnal expression of genes encoding fucoxanthin chlorophyll *a/c* polypeptides in the centric diatom *Cyclotella cryptica*. *Plant Biology* **4**, 250-257
- Oeltjen A, Marquardt J, Rhiel E** (2004) Differential circadian expression of genes *fcp2* and *fcp6* in *Cyclotella cryptica*. *International Microbiology* **7**, 127-131
- Oku O, Kamatani A** (1999) Resting spore formation and biochemical composition of the marine planktonic diatom *Chaetoceros pseudocurvisetus* un culture: ecological significance of decreased nucleotide content and activation of the xanthophyll cycle by resting spore formation. *Marine Biology* **135**, 425-436
- Olaizola M, Bienfang PK, Ziemann DA** (1992) Pigment analysis of phytoplankton during a subarctic bloom: xanthophyll cycling. *Journal of Experimental Marine Biology and Ecology* **158**, 59-74
- Olaizola M, Laroche J, Kolber Z, Falkowski PG** (1994) Non-photochemical fluorescence quenching and the diadinoxanthin cycle in a marine diatom. *Photosynthesis Research* **41**, 357-370
- Olaizola M, Yamamoto HY** (1994) Short-term response of the diadinoxanthin cycle and fluorescence yield to high irradiance in *Chaetoceros muelleri* (Bacillariophyceae). *Journal of Phycology* **30**, 606-612
- Oliver RL, Whittington J, Lorenz Z, Webster IA** (2003) The influence of vertical mixing on the photoinhibition of variable chlorophyll *a* fluorescence and its inclusion in a model of phytoplankton photosynthesis. *Journal of Plankton Research* **25**, 1107-1129
- Onno Feikema W, Marosvölgyi MA, Lavaud J, van Gorkom HJ** (2006) Cyclic electron transfer in photosystem II in the marine diatom *Phaeodactylum tricorutum*. *Biochimica et Biophysica Acta* **1757**, 829-834
- Oudot-Le Secq M-P, Grimwood J, Shapiro H, Armbrust EV, Bowler C, Green BR** (2007) Chloroplast genomes of the diatoms *Phaeodactylum tricorutum* and *Thalassiosira pseudonana*: comparison with other plastid genome of the red lineage. *Molecular Genetics and Genomics* **277**, 427-439
- Ort DR, Baker NR** (2002) A photoprotective role of O<sub>2</sub> as an alternative electron sink in photosynthesis? *Current Opinion in Plant Biology* **5**, 193-198
- Owens TG** (1986) Light-harvesting function in the diatom *Phaeodactylum tricorutum* II. Distribution of excitation energy between the photosystems. *Plant Physiology* **80**, 739-746
- Owens TG, Wold ER** (1986) Light-harvesting function in the diatom *Phaeodactylum tricorutum*. I. Isolation and characterization of pigment-protein complexes. *Plant Physiology* **80**, 732-738
- Papagiannakis E, van Stokkum IHM, Fey H, Büchel C, van Grondelle R** (2005) Spectroscopic characterization of the excitation energy transfer in the fucoxanthin-chlorophyll protein of diatoms. *Photosynthesis Research* **86**, 241-250
- Parésys G, Rigart C, Rousseau B, Wong AWM, Fan F, Barbier J-P, Lavaud J** (2005) Quantitative and qualitative evaluation of phytoplankton populations by trichromatic chlorophyll fluorescence excitation with special focus on cyanobacteria. *Water Research* **39**, 911-921
- Parker MS, Armbrust EV** (2005) Synergistic effects of light, temperature, and nitrogen source on transcription of genes for carbon and nitrogen metabolism in the centric diatom *Thalassiosira pseudonana* (Bacillariophyceae). *Journal of Phycology* **41**, 1142-1153
- Pascal AA, Caron L, Rousseau B, Lapouge K, Duval JC, Robert B** (1998) Resonance Raman spectroscopy of a light-harvesting protein from the brown alga *Laminaria saccharina*. *Biochemistry* **37**, 2450-2457
- Pascal AA, Zhenfeng L, Broess K, van Oort B, van Amerongen H, Wang C, Horton P, Robert B, Chang W, Ruban A** (2005) Molecular basis of photoprotection and control of photosynthetic light-harvesting. *Nature* **436**, 134-137
- Passaquet C, Thomas JC, Caron L, Hauswirth N, Puel F, Berkaloff C** (1991) Light-harvesting complexes of brown algae - Biochemical characterization and immunological relationships. *FEBS Letters* **280**, 21-26
- Patel D, Guganesharajah K, Thake B** (2004) Modelling diatom growth in turbulent waters. *Water Research* **38**, 2713-2725
- Patel D, Thake B, Thornton DCO** (2005) Effect of light and turbulent mixing on the growth of *Skeletonema costatum* (Bacillariophyceae). *Marine Biology* **146**, 633-644

- Paulsen H** (1995) Chlorophyll *a/b*-binding proteins. *Photochemistry and Photobiology* **62**, 367-382
- Pennington F, Guillard RRL, Liaaen-Jensen S** (1988) Carotenoid distribution patterns in Bacillariophyceae (diatoms). *Biochemical Systematics and Ecology* **16**, 589-592
- Perkins R, Mouget J-L, Lefebvre S, Lavaud J** (2006) Light response curve methodology and the application of chlorophyll fluorescence to benthic diatoms. *Marine Biology* **149**, 703-712
- Petersen JE, Sanford LP, Kemp WM** (1998) Coastal phytoplankton responses to turbulent mixing in experimental ecosystems. *Marine Ecology Progress Series* **171**, 23-41
- Pfündel E, Bilger W** (1994) Regulation and possible function of the violaxanthin cycle. *Photosynthesis Research* **42**, 89-109
- Pinto E, van Nieuwerburgh L, Paes de Barros M, Pedersen M, Colepicolo P, Snoeijis P** (2003) Density-dependent patterns of thiamine and pigment production in the diatom *Nitzschia microphala*. *Phytochemistry* **63**, 155-163
- Poulsen N, Chesley PM, Kröger N** (2006) Molecular genetic manipulation of the diatom *Thalassiosira pseudonana* (Bacillariophyceae). *Journal of Phycology* **42**, 1059-1065
- Prasil O, Zbigniew K, Berry JA, Falkowski PG** (1996) Cyclic electron flow around Photosystem II *in vivo*. *Photosynthesis Research* **48**, 395-410
- Pysznia AM, Gibbs SP** (1992) Immunocytochemical localization of photosystem I and the fucoxanthin-chlorophyll *a/c* light-harvesting complex in the diatom *Phaeodactylum tricoratum*. *Protoplasma* **166**, 208-217
- Ragni M, D'Alcala MR** (2007) Circadian variability in the photobiology of *Phaeodactylum tricoratum*: pigment content. *Journal of Plankton Research* **29**, 141-156
- Rakhimberdieva MG, Bolychevtseva YV, Elanskaya IV, Karapetyan NV** (2007a) Protein-protein interactions in carotenoid triggered quenching of phycobilisome fluorescence in *Synechocystis* sp. PCC 6803. *FEBS Letters* **581**, 2429-2433
- Rakhimberdieva MG, Vavillin DV, Vermaas WJF, Elanskaya IV, Karapetyan NV** (2007b) Phycobilin/chlorophyll excitation equilibration upon carotenoid-induced non-photochemical fluorescence quenching in phycobilisomes of the cyanobacterium *Synechocystis* sp. PCC 6803. *Biochimica et Biophysica Acta* **1767**, 757-765
- Raniello R, Lorenti M, Brunet C, Buia M-C** (2006) Photoacclimation of the invasive alga *Caulerpa racemosa* var. *cylindrica* to depth and daylight patterns and a putative role for siphonaxanthin. *Marine Ecology* **27**, 20-30
- Rascher U, Nedbal L** (2006) Dynamics of photosynthesis in fluctuating light. *Current Opinion in Plant Biology* **9**, 671-678
- Raven JA, Geider JR** (2003) Adaptation, acclimation and regulation in algal photosynthesis. In: Larkum WD, Douglas SE, Raven JA (Eds) *Photosynthesis in Algae*, Kluwer Academic Publishers, Dordrecht, The Netherlands, pp 385-412
- Rech M, Mouget J-L, Morant-Manceau A, Rosa P, Tremblin G** (2005) Long-term acclimation to UV radiation: effects on growth, photosynthesis and carbonic anhydrase activity in marine diatoms. *Botanica Marina* **48**, 407-420
- Rhiel E, Marquardt J, Eppard M, Mörschel E, Krumbein WE** (1997) The light harvesting system of the diatom *Cyclotella cryptica*. Isolation and characterization of the main light harvesting complex and evidence for the existence of minor pigment proteins. *Botanica Acta* **110**, 109-117
- Richardson K, Beardall J, Raven JA** (1983) Adaptation of unicellular algae to irradiance: an analysis of strategies. *New Phytologist* **93**, 157-191
- Rijstenbil JW** (2001) Effect of periodic, low UVA radiation on cell characteristics and oxidative stress in the marine planktonic diatom *Ditylum brightwellii*. *European Journal of Phycology* **36**, 1-8
- Rijstenbil JW** (2002) Assessment of oxidative stress in the planktonic diatom *Thalassiosira pseudonana* in response to UVA and UVB radiation. *Journal of Plankton Research* **24**, 1277-1288
- Rijstenbil JW** (2003) Effects of UVB radiation and salt stress on growth, pigments and antioxidative defence of the marine diatom *Cylindrotheca closterium*. *Marine Ecology Progress Series* **254**, 37-47
- Rijstenbil JW** (2005) UV- and salinity-induced oxidative effects in the marine diatom *Cylindrotheca closterium* during simulated emersion. *Marine Biology* **147**, 1063-1073
- Ritz M, Neverov KV, Etienne A-L** (1999) ΔpH-dependent fluorescence quenching and its photoprotective role in the unicellular red alga *Rhodella violacea*. *Photosynthetica* **37**, 267-280
- Rodrigues MA, dos Santos CP, Young AJ, Strbac D, Hall DO** (2002) A smaller impaired xanthophyll cycle makes the deep sea macroalgae *Laminaria abyssalis* (Phaeophyceae) highly sensitive to daylight when compared with shallow water *Laminaria digitata*. *Journal of Phycology* **38**, 939-947
- Round FE, Crawford RM, Mann DG** (1990) *The Diatoms. Biology and Morphology of the Genera*, Cambridge University Press, Cambridge, UK, 747 pp
- Ruban VA, Lavaud J, Rousseau B, Guglielmi G, Horton P, Etienne A-L** (2004) The super-excess energy dissipation in diatom algae: comparative analysis with higher plants. *Photosynthesis Research* **82**, 165-175
- Sakshaug E, Demers S, Yentsch CM** (1987) *Thalassiosira oceanica* and *T. pseudonana*: two different photoadaptational responses. *Marine Ecology Progress Series* **41**, 275-282
- Sarthou G, Timmermans KR, Blain S, Tréguer P** (2005) Growth physiology and fate of diatoms in the ocean: a review. *Journal of Sea Research* **53**, 25-41
- Schmitt A, Herold A, Welte C, Wild A, Wilhelm C** (1993) The light-harvesting system of a unicellular alga *Mantoniella squamata* (Prasinophyceae): evidence for the lack of a photosystem-I specific antenna complex. *Photochemistry and Photobiology* **57**, 132-138
- Schubert H, Andersson M, Snoeijis P** (2006) Relationship between photosynthesis and non-photochemical quenching of chlorophyll fluorescence in two red algae with different carotenoid compositions. *Marine Biology* **149**, 1003-1013
- Schumann A, Goss R, Torsten J, Wilhelm C** (2007) Investigation of the quenching efficiency of diatoxanthin in cells of *Phaeodactylum tricoratum* (Bacillariophyceae) with different pool sizes of xanthophyll cycle pigments. *Phycologia* **46**, 113-117
- Scott M, McCollum C, Vasil'ev S, Crozier C, Espie GS, Krol M, Huner NPA, Bruce D** (2006) Mechanism of the down regulation of photosynthesis by blue light in the cyanobacterium *Synechocystis* Sp. PCC 6803. *Biochemistry* **45**, 8952-8958
- Serodio J, Cruz S, Vieira S, Brotas V** (2005) Non-photochemical quenching of chlorophyll fluorescence and operation of the xanthophyll cycle in estuarine microphytobenthos. *Journal of Experimental Marine Biology and Ecology* **326**, 157-169
- Sigaud-Kutner TCS, Pinto E, Okamoto OK, Latorre LR, Colepicolo P** (2002) Changes in superoxide dismutase activity and photosynthetic pigment content during growth of marine phytoplankters in batch-cultures. *Physiologia Plantarum* **114**, 566-571
- Smetacek VA** (1999) Diatoms and the ocean carbon cycle. *Protist* **150**, 25-32
- Smith BM, Melis A** (1987) Photosystem stoichiometry and excitation distribution in chlotoxoplasts from the surface and minus 20 meters blades of *Macrocystis pyrifera*, the giant kelp. *Plant Physiology* **84**, 1325-1330
- Staehr PA, Henriksen P, Markager S** (2002) Photoacclimation of four marine phytoplankton species to irradiance and nutrient availability. *Marine Ecology Progress Series* **238**, 47-59
- Standfuss J, van Scheltinga ACT, Lamborghini M, Kühlbrandt W** (2005) Mechanisms of photoprotection and nonphotochemical quenching in pea light-harvesting complex at 2.5 Å resolution. *The EMBO Journal* **24**, 919-928
- Staubert JL, Jeffrey SW** (1988) Photosynthetic pigments in fifty-one species of marine diatoms. *Journal of Phycology* **24**, 158-172
- Stransky H, Hager A** (1970) Das Carotinoidmuster und die Verbreitung des lichtinduzierten Xanthophyll-Cyclus in verschiedenen Algenklassen. VI Chemosystematische Betrachtung. *Arkiv für Mikrobiologie* **75**, 315-323
- Stroch M, Spunda V, Kurasova I** (2004) Non-radiative dissipation of absorbed excitation energy within photosynthetic apparatus of higher plants. *Photosynthetica* **42**, 323-337
- Strzepek RF, Harrison PJ** (2004) Photosynthetic architecture differs in coastal and oceanic diatoms. *Nature* **431**, 689-692
- Swiatek M, Kuras R, Sokolenko A, Higgs D, Olive J, Cinque G, Muller B, Eichacker LA, Stern DB, Bassi R, Herrmann RG, Wollman FA** (2001) The chloroplast gene *yef9* encodes a photosystem II (PSII) core subunit, PsbZ, that participates in PSII supramolecular architecture. *The Plant Cell* **13**, 1347-1367
- Szabo M, Lepetit B, Goss R, Wilhelm C, Mustardy L, Garab G** (2007) Structurally flexible macro-organization of the pigment-protein complexes of the diatom *Phaeodactylum tricoratum*. *Photosynthesis Research* in press
- Tada N, Shibata S, Otsuka S, Namba K, Oyaizu O** (1999) Comparison of gene arrangements of chloroplasts between two centric diatoms, *Skeletonema costatum* and *Odontella sinensis*. *DNA Sequence* **10**, 343-347
- Takishita K, Ishida K-I, Maruyama T** (2004) Phylogeny of nuclear-encoded plastid-targeted GAPDH gene supports separate origins for the peridinin- and the fucoxanthin derivative-containing plastids of dinoflagellates. *Protist* **155**, 447-458
- Ting CS, Owens TG** (1993) Photochemical and non-photochemical fluorescence quenching processes in the diatom *Phaeodactylum tricoratum*. *Plant Physiology* **101**, 1323-1330
- Tozzi S, Schofield O, Falkowski PG** (2004) Historical climate change and ocean turbulence as selective agents for two key phytoplankton functional groups. *Marine Ecology Progress Series* **274**, 123-132
- Tréguer P, Pondaven P** (2000) Silica control of carbon dioxide. *Nature* **406**, 358-359
- van de poll WH, van Leeuwe MA, Roggeveld J, Buma AGJ** (2006) Nutrient limitation and high irradiance acclimation reduce PAR and UV-induced viability loss in the antarctic diatom *Chaetoceros brevis* (Bacillariophyceae). *Journal of Phycology* **41**, 840-850
- van de poll WH, Visser RJW, Buma AGJ** (2007) Acclimation to a dynamic irradiance regimes changes excessive irradiance sensitivity of *Emiliana huxleyi* and *Thalassiosira weissflogii*. *Limnology and Oceanography* **52**, 1430-1438
- van Leeuwe MA, van Sikkelerus B, Gieskes WWC, Stefels J** (2005) Taxon-specific differences in photoacclimation to fluctuating irradiance in an Antarctic diatom and a green flagellate. *Limnology and Oceanography* **288**, 9-19
- Veith T, Büchel C** (2007) The monomeric Photosystem I-complex of the diatom *Phaeodactylum tricoratum* binds specific fucoxanthin chlorophyll proteins (FCPs) as light-harvesting complexes. *Biochimica Biophysica Acta* in

- press
- Villareal TA, Pilskaln C, Brzezinski A, Lipschultz F, Dennett M, Gardner GB** (1999) Upward transport of oceanic nitrate by migrating diatom mats. *Nature* **397**, 423-425
- Wagner H, Jakob T, Wilhelm C** (2006) Balancing the energy flow from captured light to biomass under fluctuating light conditions. *New Phytologist* **169**, 95-108
- Whimarsh J, Pakrasi HB** (1996) Form and function of Cytochrome *b*-559. In: Ort DR, Yocum CF (Eds) *Oxygenic Photosynthesis: The Light Reactions*, Kluwer Academic Publishers, Dordrecht, pp 249-264
- Wilhelm C** (1990) The biochemistry and physiology of light-harvesting processes in chlorophyll *b*- and chlorophyll *c*-containing algae. *Plant Physiology and Biochemistry* **28**, 293-306
- Wilhelm C, Becker A, Toepel J, Vieler A, Rautenberger R** (2003) Photophysiology and primary production of phytoplankton in freshwater. *Physiologia Plantarum* **120**, 347-357
- Wilhelm C, Büchel C, Fisahn J, Goss R, Jakob T, LaRoche J, Lavaud J, Lohr M, Riebesell U, Stehfest K, Valentin K, Kroth P** (2006) The regulation of carbon and nutrient assimilation in diatoms is significantly different from green algae. *Protist* **157**, 91-124
- Willemoës M, Monas E** (1991) Relationship between growth irradiance and the xanthophyll cycle pool in the diatom *Nitzschia palea*. *Physiologia Plantarum* **83**, 449-456
- Wilson A, Ajlani G, Verbavatz J-M, Vass I, Kerfeld CA, Kirilovsky D** (2006) A soluble carotenoid protein involved in phycobilisome-related energy dissipation in cyanobacteria. *The Plant Cell* **18**, 992-1007
- Wilson A, Boulay C, Wilde A, Kerfeld CA, Kirilovsky D** (2007) Light-induced energy dissipation in iron-starved cyanobacteria: roles of OCP and IsiA proteins. *The Plant Cell* **19**, 656-672
- Wittpoth C, Kroth P, Weyrauch K, Kowallik KV, Strotmann H** (1998) Functional characterization of isolated plastids from two marine diatoms. *Planta* **206**, 79-85
- Wolfe-Simon F, Starovoytov V, Reinfelder JR, Schofield O, Falkowski PG** (2006) Localization and role of manganese superoxide dismutase in a marine diatom. *Plant Physiology* **142**, 1701-1709
- Wulff A, Wängberg S-T, Sundbäck K, Nilsson C, Underwood GJC** (2000) Effects of UVB radiation on a marine microphytobenthic community growing on a sand-substratum under different nutrient conditions. *Limnology and Oceanography* **45**, 1144-1152
- Zudaire L, Roy S** (2001) Photoprotection and long-term acclimation to UV radiation in the marine diatom *Thalassiosira weissflogii*. *Journal of Photochemistry and Photobiology B* **62**, 26-34